

TM 10-3990-203-13&P

TECHNICAL MANUAL

OPERATOR'S, UNIT, INTERMEDIATE DIRECT SUPPORT MAINTENANCE MANUAL (INCLUDING REPAIR PARTS INFORMATION)

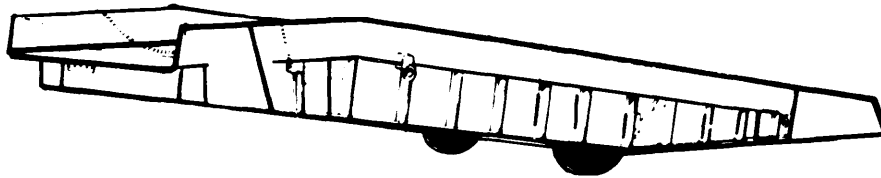

**RAMP, MOBILE LOADING,
16,000lb. MAGLINE MODEL
MDS-16-92-36-6F-AS-12C
(NSN 3990-01-121-7758)**

**SECTION I
GENERAL DATA SECTION 1-1**

**SECTION II
PREPARATION FOR USE 2-1**

**SECTION III
THEORY OF OPERATION 3-1**

**SECTION IV
OPERATING INSTRUCTIONS 4-1**

**SECTION V
MAINTENANCE INSTRUCTIONS 5-1**

**SECTION VI
REPAIR PARTS LIST 6-1**

**APPENDIX A
PUBLICATION REFERENCES A-1**

**APPENDIX B
SUPPLEMENTAL OPERATING
MAINTENANCE AND
REPAIR PARTS INSTRUCTIONS
W/MAINTENANCE
ALLOCATION CHART B-1**

WARNING

Due to the weight and turning radius of rough terrain forklifts special care should be exercised in utilizing platforms with the ramp (Fig. 4-3).

WARNING

Secure the ground end of the ramp to prevent the ramp from sliding off the blocks.

WARNING

Place the undercarriage up on blocks high enough to allow the wheels to turn before proceeding.

TECHNICAL MANUAL

No. 10-3990-203-13&P



HEADQUARTERS
DEPARTMENT OF THE ARMY
Washington, D.C., 30 January 1987

OPERATOR'S, UNIT, INTERMEDIATE
DIRECT SUPPORT MAINTENANCE MANUAL
(INCLUDING REPAIR PARTS INFORMATION)
FOR

RAMP, MOBILE LOADING, 16000 lb.
MAGLINE MODEL MDS-16-92-36-6F-AS-12C
(NSN 3990-01-121-7758)

REPORTING ERRORS AND RECOMMENDING IMPROVEMENTS

You can help improve this manual. If you find any mistakes or if you know of a way to improve the procedures, please let us know. Mail your letter, DA Form 2028 (Recommended Changes to Publications and Blank Forms), or DA Form 2028-2 located in the back of this manual directly to: Commander, US Army Tank-Automotive Command, ATTN: AMSTA-MB, Warren, MI 48397-5000. A reply will be sent to you.

Section		Paragraph	Page
I	INTRODUCTION		1-1
	Introduction	1.	1-1
	Scope	1.1	1-1
	Purpose	1.2	1-1
	Capabilities and Performance Requirements	1.3	1-1
	Leading Particulars	1.4	1-1
	Unattached Parts	1.5	1-3
	Warranty	1.6	1-3
II	PREPARATION FOR USE		2-1
	Unattached Parts	2.	2-1
	Shipping Plug	2.2	2-1
	Safety Chain Assembly	2.3	2-1
III	GENERAL THEORY OF OPERATION		3-1
	Purpose	3.	3-1
	Operating Features	3.2	3-1
IV	OPERATING INSTRUCTIONS		4-1
	Ramp Use	4.	4-1
	Towing	4.1	4-1
	Position for Use	4.2	4-1
	Removal from Service	4.3	4-2
V	MAINTENANCE INSTRUCTIONS		5-1
	Maintenance	5.	5-1
	Cleaning	5.1	5-1
	Lubrication	5.2	5-1
	Troubleshooting	5.3	5-1
	Inspection	5.4	5-1
	Disassembly, Repair or Replacement, and Reassembly	5.5	5-4

Section	Paragraph	Page
VI	ILLUSTRATED PARTS LIST	6-1
	Introduction	6-1
	Parts List Illustrations	6.2
	Manufacturer's Code List	6.3
	Numerical Index	6.4
	Group Assembly Parts List	6.5
APPENDIX A		A-1
Publication References		
APPENDIX B		B-1
Supplemental Operating		
Maintenance and Repair		
Parts Instructions W/Mac		
APPENDIX C		C-1
Lubricants		

LIST OF ILLUSTRATIONS

Figure No.		Page No.	Figure No.		Page No.
1-1	Ramp Assemblies	1-2	5-7	Hub Assembly	5-9
2-1	Breather Plug Installation . .	2-2	5-8	Grating and Clamps	
2-2	Safety Chain/Lift Ring			Assembly	5-11
	Location	2-3	5-9	Air Spring Assembly	5-13
2-3	Safety Chain Assembly	2-3	5-10	Hydraulic System - Location .	5-14
4-1	Towbar Position	4-2	5-11	Hydraulic Pump Assembly . .	5-15
4-2	Pump Handle / Storage Tube .	4-3	5-12	Hydraulic Lift Cylinder	
4-3	Ramp Alignment Examples . .	4-4	5-13	Exploded View	5-18
4-4	Pump Control Valve -			Hydraulic Lift Cylinder	
	Location	4-5	5-14	Assembly	5-20
4-5	Pump Handle Into Beam -			Hydraulic Lines	5-21
	Location	4-6	6-1	Ramp and Attaching Parts . .	6-4
5-1	Yoke Assembly -		6-2	Attaching Parts Assemblies .	6-6
	Lubrication	5-1	6-3	Grating/Clamp Assembly . . .	6-8
5-2	Hub Assembly - Lubrication .	5-2	6-4	Towbar	6-10
5-3	Towbar Assembly	5-5	6-5	Suspension, Yoke, Wheels,	
5-4	Frame Bracket Assembly . .	5-7	6-6	Tires	6-12
5-5	Reflector Assembly	5-7	6-7	Hydraulic pump	6-14
5-6	Undercarriage Assembly . . .	5-8	6-8	Hydraulic Lift Cylinders . . .	6-16
				Hydraulic Lines and Fittings .	6-18

LIST OF TABLES

Table No.		Page No.	Table No.		Page No.
			5-1	Troubleshooting Guide	5-2
			5-2	Inspection Guide	5-4
2-1	Parts Box - Contents	2-1	5-3	Pump Repair Kit 3024	5-16

This technical manual is an authentication of the manufactures commercial literature and does not conform with the format and content specified in AR 310-3, Military Publications. This technical manual does. however, contain valuable information that is essential to the operation and maintenance of the equipment

"This publication contains technical or operational information that is for offical Government use only Distribution is limited to U.S. Government agencies. Requests from outside U.S. Government for release of this publication under the Freedom of Information Act or the Foreign Military Sales Program must be made to U.S. Army Tank-Automotive Command ATTN: AMSTA-MB Warren. M1 48397-5000

SECTION I

INTRODUCTION

1. INTRODUCTION

1.1 SCOPE

1.1.1 This manual contains instructions for towing, using, and maintaining the Magline Mobile Loading Ramp, Model Number MDS-16-92-36-6F-AS-12C (Fig. 1-1), hereinafter referred to as the ramp. This manual contains descriptions of procedures for inspecting, maintaining, disassembling, repairing, and reassembling:

- a. the yoke
- b. the suspension
- c. the hydraulic system
- d. the towbar
- e. the grating
- f. any special purpose components

1.2 PURPOSE

1.2.1 The ramp shall be used for loading and unloading functions requiring the use of 4,000 pound capacity rough terrain and depot forklift trucks. It allows the lift truck to ascend, from ground level, to the floor of a MILVAN or refrigerated container, pick up or drop off goods, and return to the ground.

1.3 CAPABILITIES AND PERFORMANCE REQUIREMENTS

1.3.1 The ramp is constructed to meet or surpass the requirements set forth in MIL-R-52899A(ME).

a. Aluminum frame construction with I-beam trusses for support. It is capable of supporting a 16,000 lb workload.

b. Four sections of steel grating, mechanically fastened to the frame. The grating clamps can be removed to allow removal of a grated section.

c. The ramp is designed to perform with carrier heights (working surfaces) ranging from 45 to 65 inches high. When the service apron (high end) is at a height of 62 inches, the 72 inch level off portion is parallel to the ground.

d. The ramp is 36 feet long with a usable width of 88 3/4 inches at the entry apron and 84 inches at the service apron. A 14 inch lip on the service apron rests on the work surface.

e. Both ends of the ramp are of safety tread plate styling.

f. The hydraulic system is manually operated and located completely within the interior of the ramp. A use port is cut in the ramp wall giving use access to the pump. The complete hydraulic system can be reached from underneath the ramp or by removing a section of grating.

g. A detachable towbar is utilized and storage is provided in the frame construction (Fig. 1-1). The towbar shall be used with pintle or hook type hitches.

h. Hand holds are built into both sides of the frame allowing manual maneuverability. Balanced design aids manual positioning.

i. Manual positioning allows the ramp to be used in areas where working space is limited.

j. Materials used to construct the ramp allow it to be used in all environments.

k. The suspension consists of two Goodyear air springs with internal rubber bumpers. The ramp tires are two 8 x 14.5 LT, load range F pneumatic tires. The bumpers provide a safety stop in the event of low air pressure in the air springs, preventing the ramp from bottoming out.

1.4 LEADING PARTICULARS

Overall Length	36 Feet (432 Inches)
Overall Width	92 Inches
Usable Width, Entry	88 3/4 Inches
Usable Width, Service	84 Inches
Minimum Height	45 Inches
Maximum Height	65 Inches
Weight	Approximately 5,000 Lbs
Workload Capacity	16,000 Lbs
Center of Gravity	221 Inches from Entry
Track	60 Inches
Clearance, Ground to Axle	26 Inches
Upper Grating Width	39 3/8 Inches Nominal
Upper Grating Length	47 3/4 Inches Nominal
Lower Grating Width	39 3/8 Inches Nominal
Lower Grating Length	310 Inches Nominal
Towing Speeds:	
Improved Roads	25 MPH
Cross Country	5 MPH

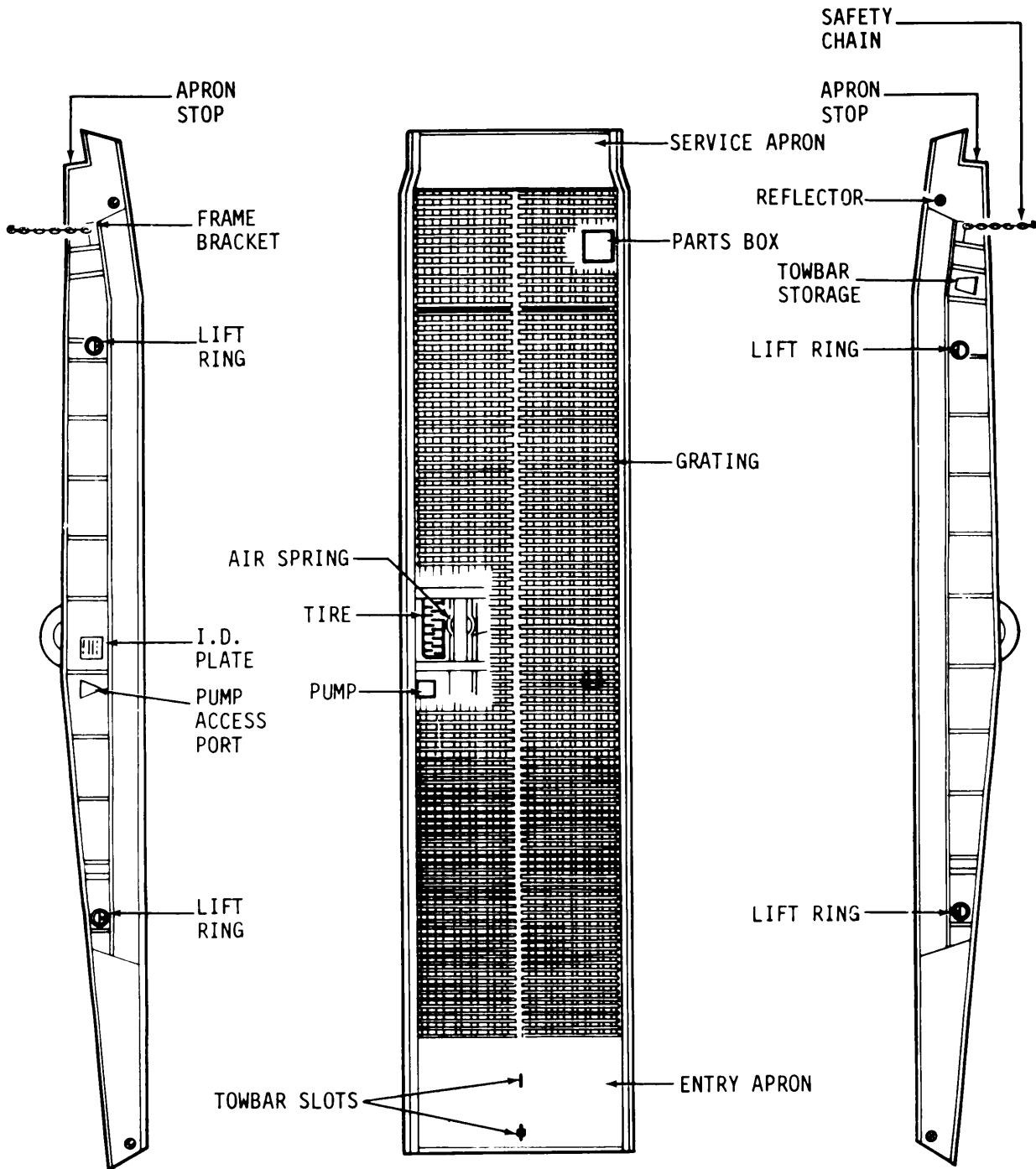

Figure 1-1. Ramp Assemblies

1.5 UNATTACHED PARTS

1.5.1 A parts box (Fig. 1-1) is fastened underneath the right side of the grating near the service end. Table 2-1 lists the items packed in the box.

1.5.2 All tools required for maintaining and repairing the ramp are common tools.

1.6 WARRANTY

1.6.1 Notwithstanding inspection and acceptance by the Government of the supplies furnished under the

contract or any provision of the contract concerning the conclusiveness thereof, the contractor hereby warrants that the supplies are free from defects in material and workmanship and will conform with the specifications and all other requirements of the contract for a period of 15 months from date of acceptance, as shown on the Material Inspection and Receiving Report (DD Form 250).

1.6.2 Warranty claims shall be requested by completing DA Form 2407 IAW TM 738-750 and submitted to Commander, US Army TACOM, ATTN: AMSTA-MW, Warren, MI. 48397-5000. Inquiries to DA Form 2407 shall include the ramp serial number, found on the I.D. plate (Fig. 1-1), and the part number of the subject part as identified in the Illustrated Parts List (when applicable).

SECTION II

PREPARATION FOR USE

2. UNATTACHED PARTS

2.1 Special, minor assemblies shall be completed before the ramp is considered completely assembled and ready for use. The parts for these assemblies are shipped in the attached parts box (para. 1.5.1). Table 2-1 lists the parts in the box.

2.2 SHIPPING PLUG

2.2.1 To maintain proper oil level in the hydraulic system during shipping, a temporary shipping plug has been inserted at the top of the hydraulic pump reservoir (Fig. 2-1). This plug shall be removed and replaced with a breather plug (Table 2-1).

2.2.2 To change the plug, approach the pump through the pump access port on the left side of the ramp (Fig. 1-1). Using a 7/16 inch box wrench, loosen and remove the shipping plug (Fig. 2-1).

NOTE

Store the shipping plug, do not discard it. Reshipment of the ramp will require changing the plug again.



Do not overtighten the breather plug causing the threads to strip.

2.2.3 Take the breather plug from the special parts box (Table 2-1). Insert the breather plug into the threaded hole where the shipping plug was removed

and tighten it by hand. Using a 7/16 inch box wrench, tighten the plug securely.

NOTE

Hydraulic fluid level should be at the bottom of plug opening. Fluid should be added with the ramp in the lower position using hydraulic fluid, Military Specification MIL-H-5606C, NSN-9150-00-252-6383.

2.3 SAFETY CHAIN ASSEMBLY

2.3.1 There are two safety chain assemblies (Table 2-1), one for each side of the service end of the ramp (Fig. 2-2). The chains have hooks on one end and are attached to mounting plates with shackles on the opposite ends (Fig. 2-3).

2.3.2 Take one safety chain assembly from the special parts box (Table 2-1). The chains shall be attached to the ramp by bolting the mounting plate to the frame bracket (Fig. 2.-3).

2.3.3 Line up the holes in the mounting plate with the holes in the frame bracket. The chain shall be towards the service end of the ramp. From the outside of the mounting plate insert a 1/2-13 x 1 1/4 hex head capscrew (Table 2-1) through the top hole (Fig. 2-3). From the backside of the frame bracket, thread one of the 1/2-13 locknuts onto the end of the cap-screw and tighten by hand. Repeat the fastening procedure for the bottom hole. Using a 3/4 inch box wrench on the locknuts and a 3/4 inch socket and ratchet, tighten the fasteners securely. Attach the second safety chain assembly to the opposite side of the ramp by repeating the entire procedure.

Table 2-1. Parts Box - Contents

PART NUMBER	NOMENCLATURE	QUANTITY
310804	Safety Chain Assembly Consisting Of:	2
83026	Eye Grab Hook	1 per Assy
83027	1/4" Connecting Link	1 per Assy
83030	1/4" x 8' Chain	1 per Assy
83029	1/4" Shackle with Pin	1 per Assy
310806	Mounting Plate	1 per Assy
80048	Mounting Bolts	2 per Assy
80606	Hex Locknuts	2 per Assy
55550	Breather Plug - Hydraulic Pump	1
310999	Manual	2

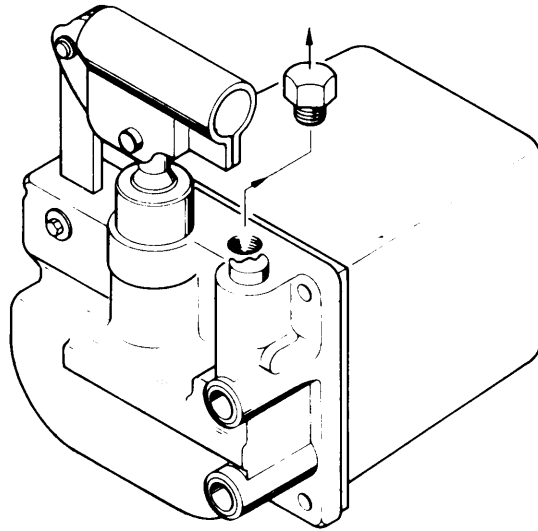

SHIPPING
PLUG

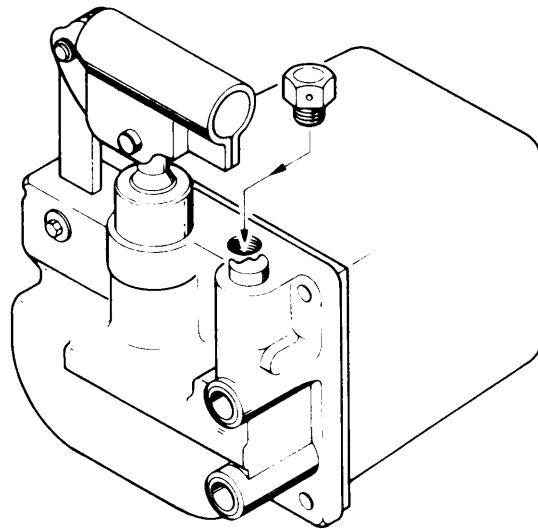

BREATHER (FILL)
PLUG

Figure 2-1. Breather Plug-Installation

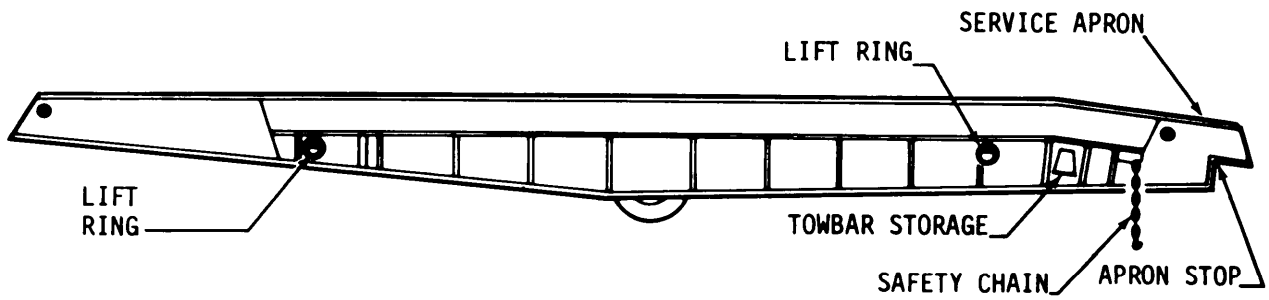

Figure 2-2. Safety Chain/Lift Ring Locations

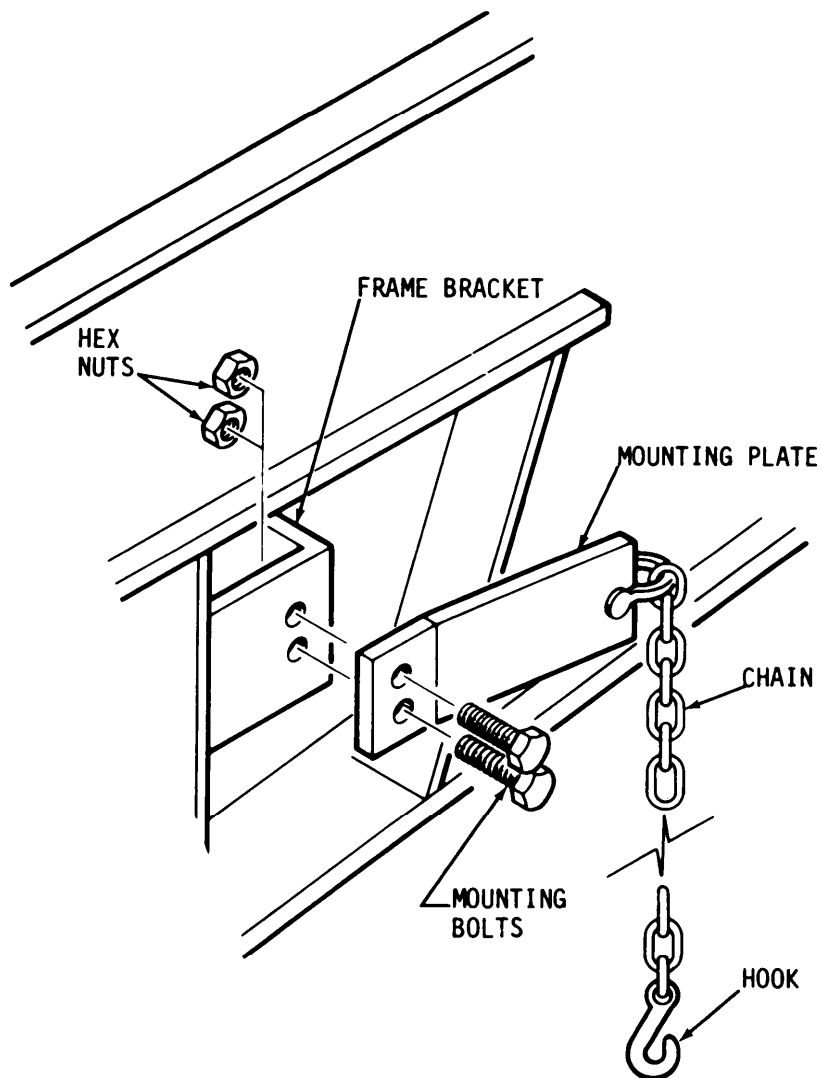

Figure 2-3. Safety Chain-Assembly

SECTION III

GENERAL THEORY OF OPERATION

3. PURPOSE

3.1 The MDS-16-92-36-6F-AS-12C loading ramp shall be used to aid loading and unloading procedures where one operating level is physically higher than the other, such as from the ground to a container or MILVAN. It is constructed for use with both rough terrain and depot forklift trucks.

3.2 OPERATING FEATURES

3.2.1 The ramp features:

- a. A detachable towbar, used to tow the ramp from storage to the work site.
- b. Capabilities to be positioned manually to the container, vehicle, etc.
- c. A hydraulic system used to elevate the forward apron (service end) of the ramp above the work surface.
- d. Safety chains to secure the ramp to the work surface.

SECTION IV

OPERATING INSTRUCTIONS

4. RAMP USE

4.1 TOWING

NOTE

General operating instructions shall be on an instruction plate attached to the ramp near the hydraulic pump (Fig. 1-1).

4.1.1 Remove towbar from the towbar storage compartment on the right side of the ramp (Fig. 1-1). Attach the towbar to the entry apron of the ramp (Fig. 4-1).

a. Block the wheels to prevent the ramp from rolling and elevate the entry apron 18 - 24 inches and support it with a block.

b. Place the towbar over the entry apron and align the T-locks with the slots in the apron. Place the towbar into position with the block seated in the plate cutout (Fig. 4-1).

NOTE

The T-locks should be threaded down as far as possible.

c. Rotate the T-locks 90° and pull upward on the roll pins, engaging the ends of the clamps into the round holes on either side of the slots.



T-lock handles must be tightened securely. Check for tightness and compression of lock washers.

d. Secure the towbar by turning the handle on the lock downward.

e. Attach the eye of the towbar to the vehicle hitch.



Pump control valve shall be in LOWER position while the ramp is being towed.

f. Remove wheel blocks and tow to the work area; 25 MPH on improved roads or 5 MPH cross country.

g. Reverse the procedure to remove the towbar and put it in the storage compartment before putting the ramp in position for use.

4.2 POSITION FOR USE

4.2.1 The ramp can be setup in a direct alignment with the work surface or in an indirect alignment with the work surface (Fig. 4-3).

4.2.2 Direct Alignment

a. Position the high end of the ramp towards the work surface (Fig. 4-3).

b. Remove the pump handle from the pump storage tube (Fig. 4-2).

c. Insert the pump handle thru the pump access port and into the pump beam (Fig. 4-5).

d. Place the pump control valve in the RAISE position (Fig. 4-4).

e. Pump up the high end of the ramp so that it is 2 -3 inches above the work surface.

f. Butt the apron stops (Fig. 2-2) up to the outer edge of the work surface.

g. Place the pump control valve in the LOWER position (Fig. 4-4). The ramp will then settle to rest upon the work surface.



Keep the pump control valve in the LOWER position while the ramp is being used. Failure to do so may cause excessive pressure in the hydraulic pump and on the wheels and axle causing extensive damage.

h. Place the pump handle back into the storage tube (Fig. 4-2).

i. Attach the hooks on the safety chains to the frame of the work vehicle.

4.2.3 Indirect Alignment

4.2.3.1 When the working area directly behind the work surface is limited, such as a railyard or crowded shipping yard, and there is not enough room to set the ramp up directly in line with the work surface, the ramp may be used with a platform to gain access to the work surface (Fig. 4-3).

WARNING

Due to the weight and turning radius of rough terrain forklifts, special care should be exercised in utilizing platforms with the ramp (Fig. 4-3).

a. Set a platform next to the work surface. Join the work surface and the platform with a dock plate. The platform then extends and becomes part of the work surface.

b. Position the ramp along the work surface and to the platform using the same procedure used in the direct alignment.

4.3 REMOVAL FROM SERVICE

a. Remove the safety chains from the work vehicle. Place the chains over the ramp surface and hook the right and left safety hooks together. This is the towing position for the safety chains.

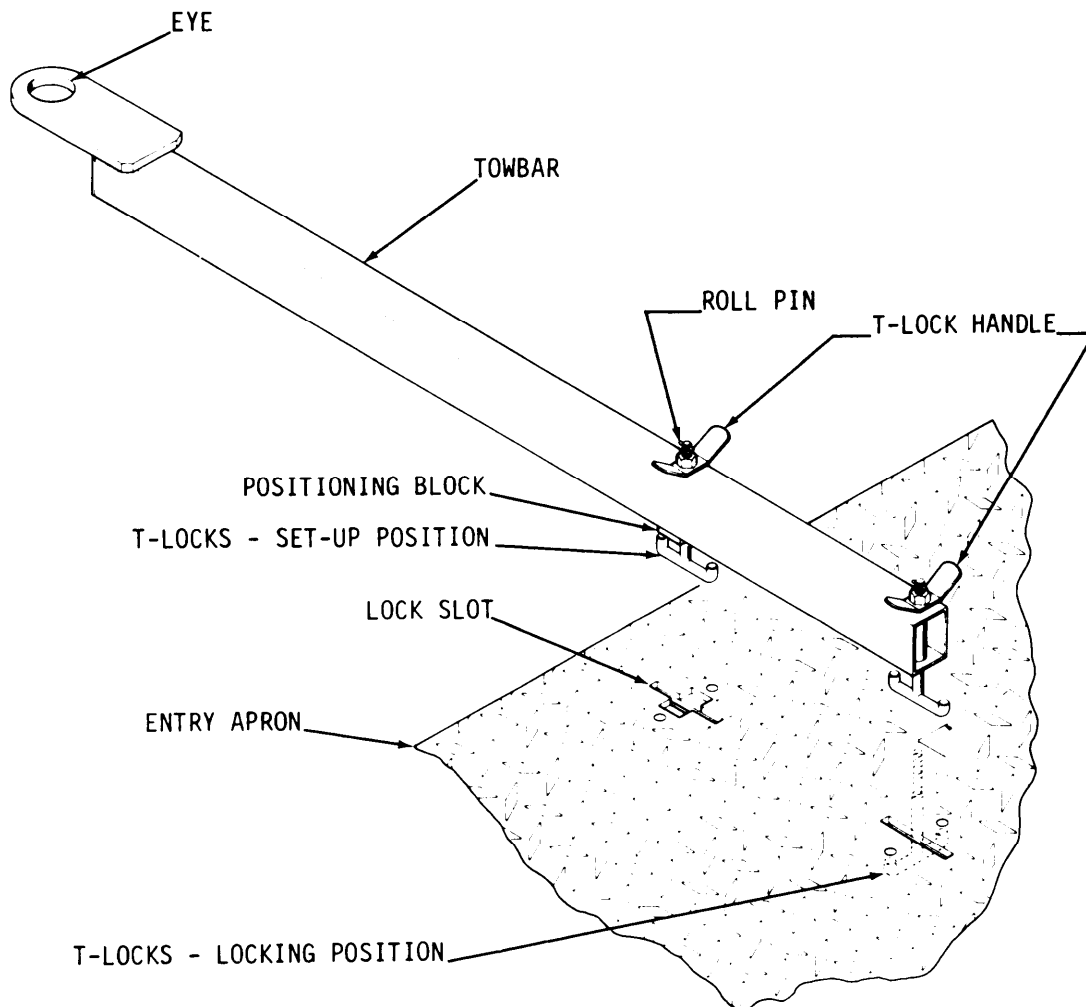

Figure 4-1. Towbar Position

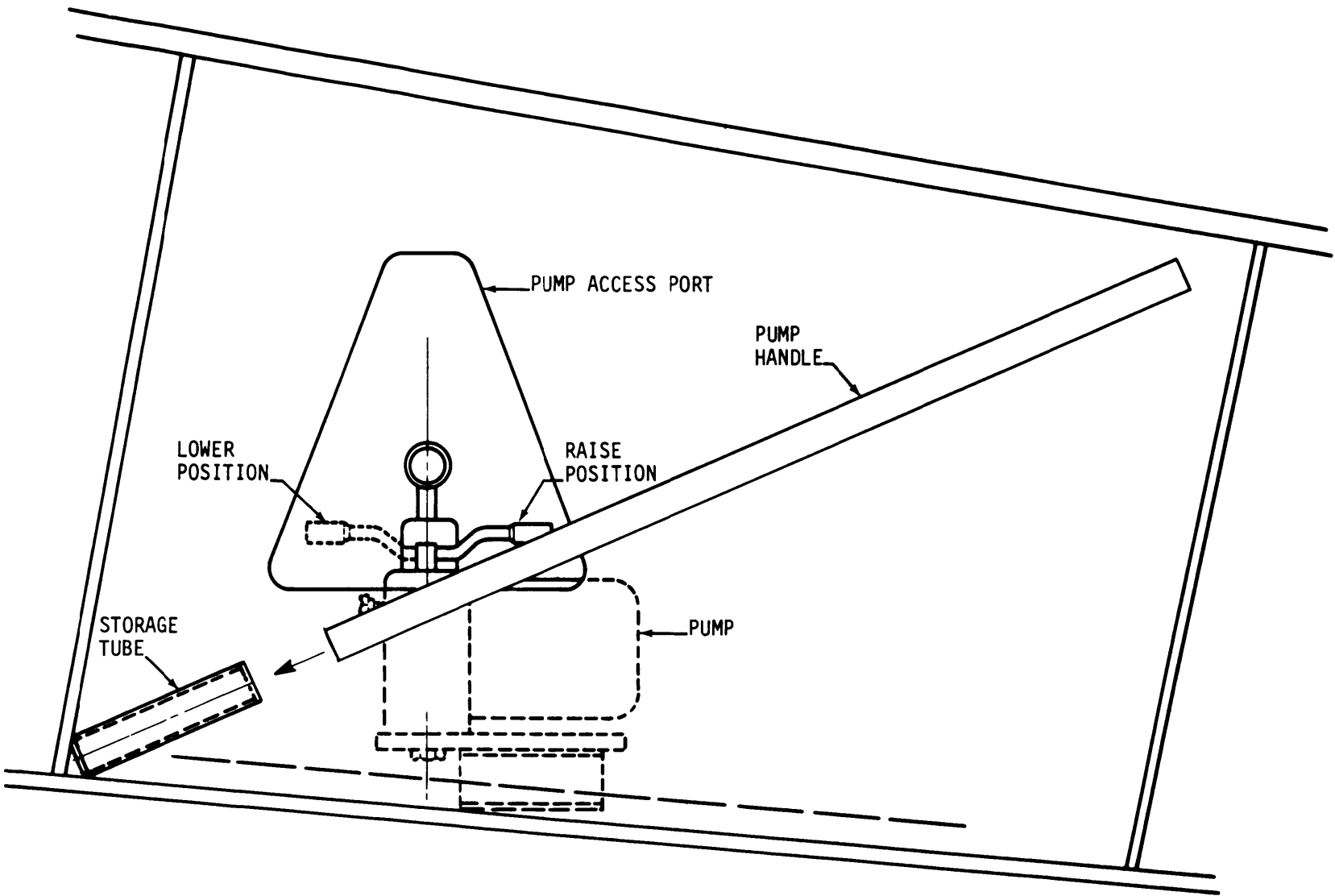
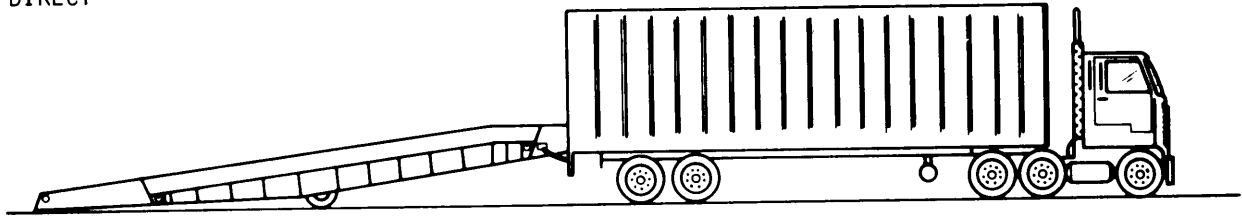
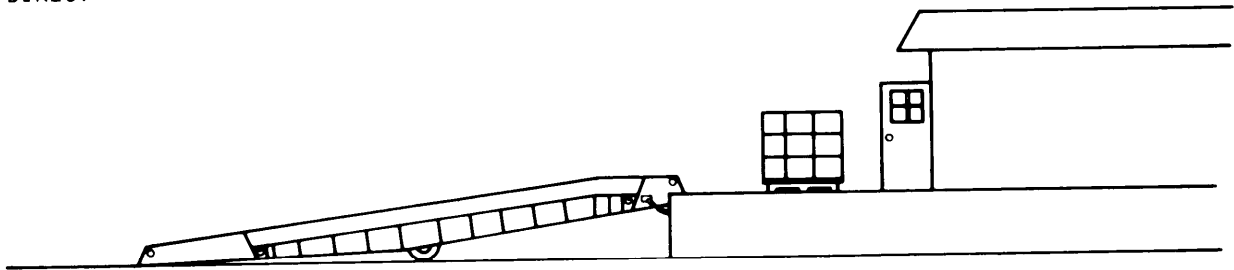

Figure 4-2. Pump Handle / Storage Tube

DIRECT



DIRECT



DIRECT

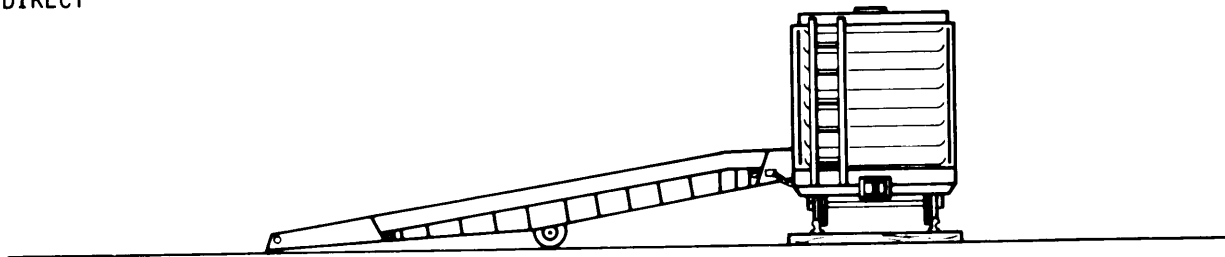

INDIRECT

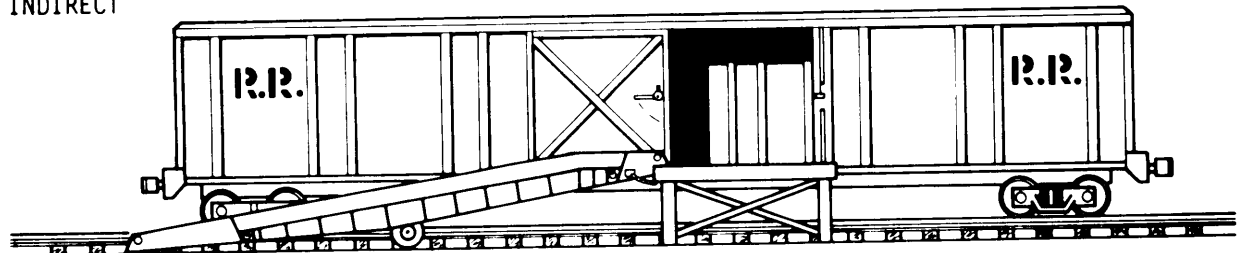

INDIRECT

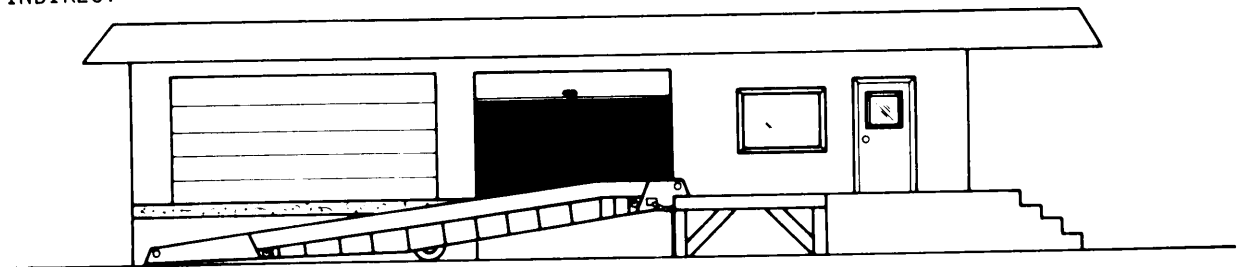

Figure 4-3. Ramp Alignment Examples

- b. Take the pump handle from the storage tube and position it in the pump beam (Fig. 4-5).
- c. Place the pump control valve in the RAISE position (Fig. 4-4).
- d. Raise the service apron above the work surface.
- e. Pull the ramp away from the work vehicle.
- f. Place the pump control valve in the LOWER position.
- g. Place the pump handle into the storage tube (Fig. 4-2).
- h. Take the towbar from the storage compartment (Fig. 2-2) and attach it to the ramp para. 4.1.1).

- i. Place the ramp in position behind the towing vehicle.
- j. Attach the towbar eye to the towing vehicle hitch.

CAUTION

Pump control valve shall be in the LOWER position while towing. Failure to do so may cause excessive pressure in the hydraulic pump and on the wheels and axle causing extensive damage.

- k. Tow the ramp to the storage site. Proceed with an inspection of the ramp when at the storage site.

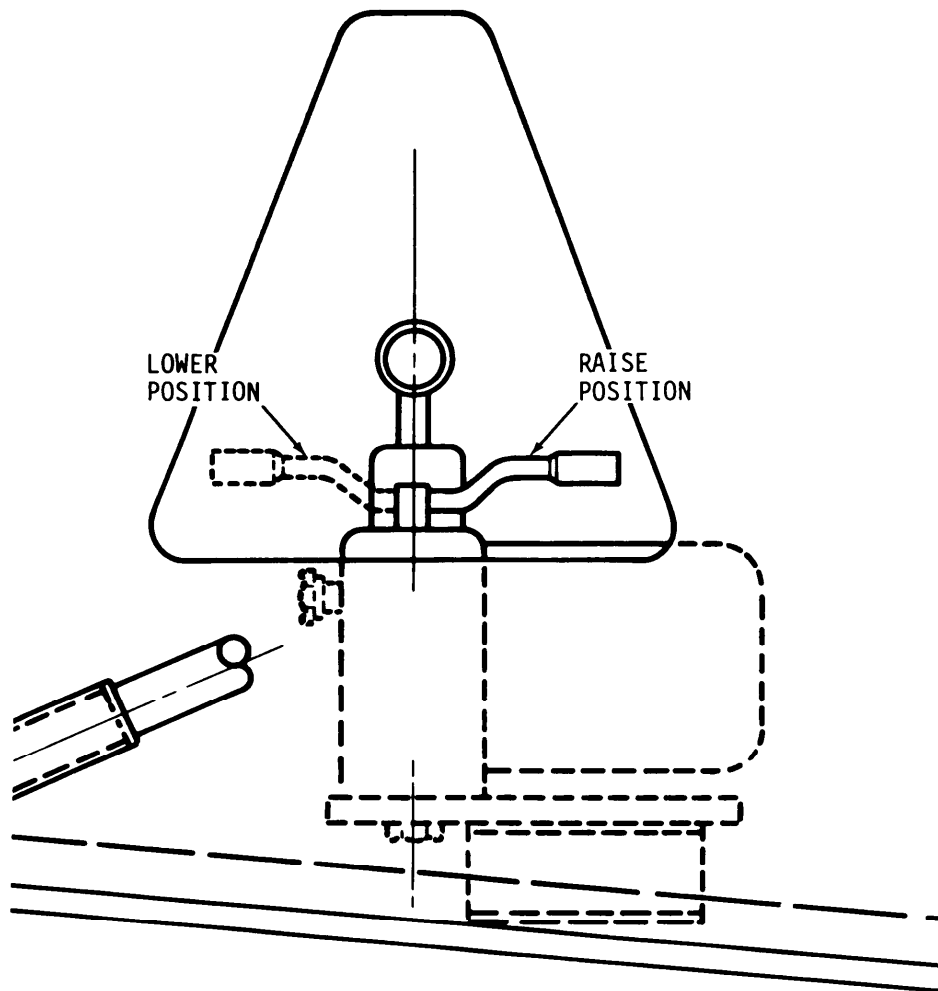

Figure 4-4. Pump Control Valve - Location

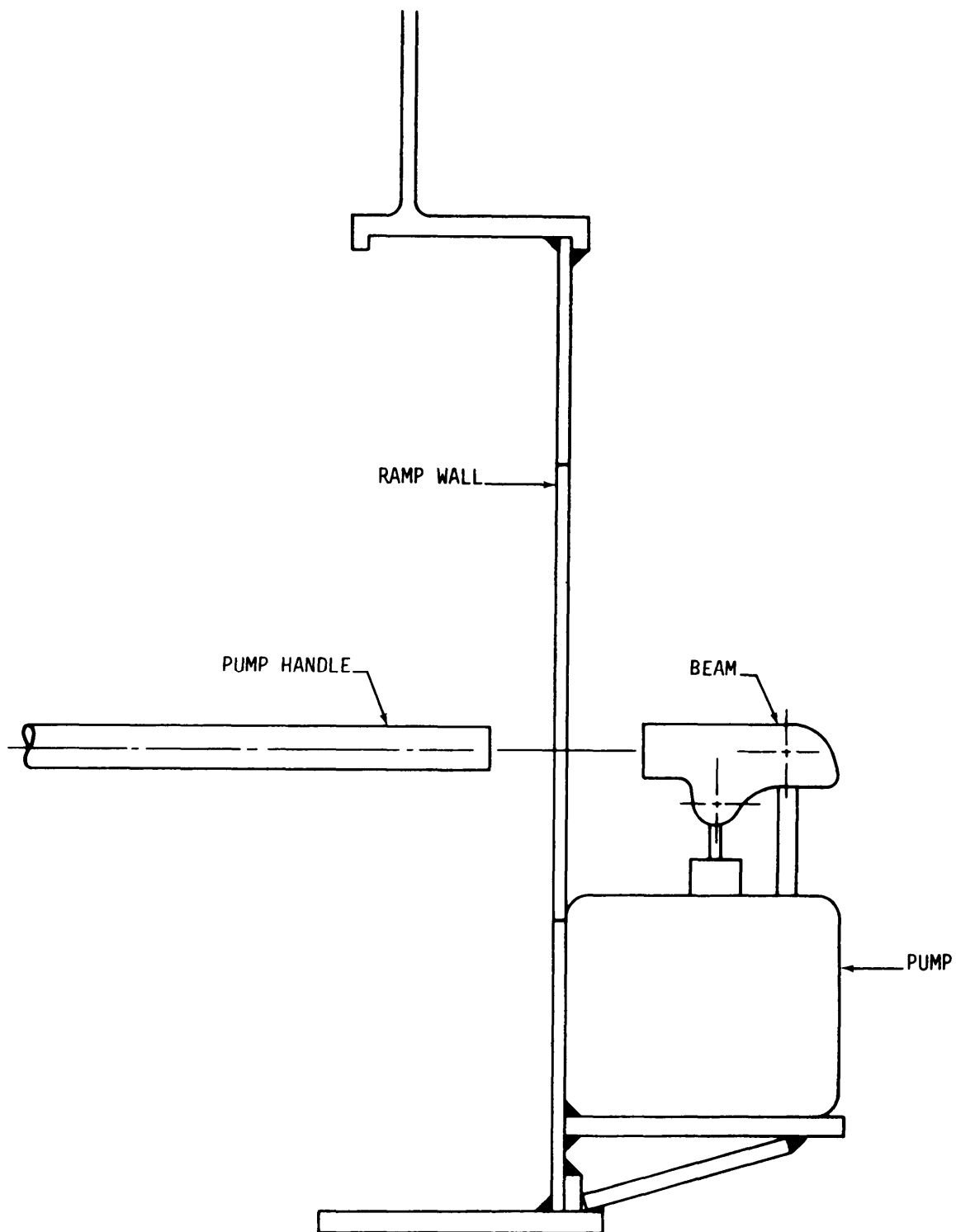

Figure 4-5. Pump Handle Into Beam - Location

SECTION V

MAINTENANCE INSTRUCTIONS

5. MAINTENANCE

5.1 CLEANING

5.1.1 Clean the ramp of surface dirt, mud, and grime when they appear. Use a spray of water from a hose, such as a power wash.

5.2 LUBRICATION

5.2.1 The pivot pin from the yoke assembly (Fig. 5-1) and the wheel bearings, part nos. 18012/18013 and 18047/18048 (Fig. 5-2) shall be lubricated with a waterproof automotive grease, Military Specification MIL-G-10924, or equivalent every six months.

5.2.2 The pivot pin can be greased by applying grease with a hand operated grease gun with a 10 inch

flexible extension. Place the end of the extension over the grease fitting on the pivot tubes in the under-carriage assembly.

5.2.3 Lubricating the wheel bearings is covered in reassembly procedures.

5.3 TROUBLESHOOTING

5.3.1 Troubleshooting procedures are contained in Table 5-1.

5.4 INSPECTION

5.4.1 A spot inspection after each use can determine if the ramp is ready for storage or is in need of maintenance. Table 5-2 lists the ramp assemblies and what to look for during an inspection.

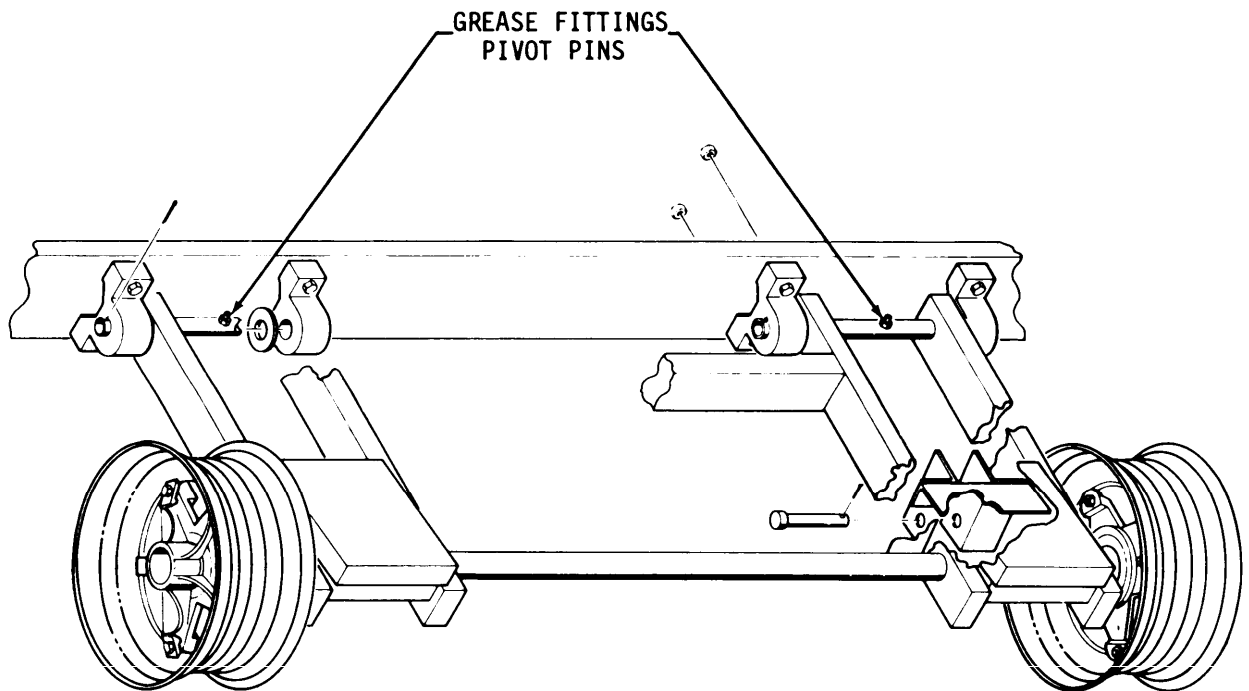

Figure 5-1. Yoke Assembly - Lubrication

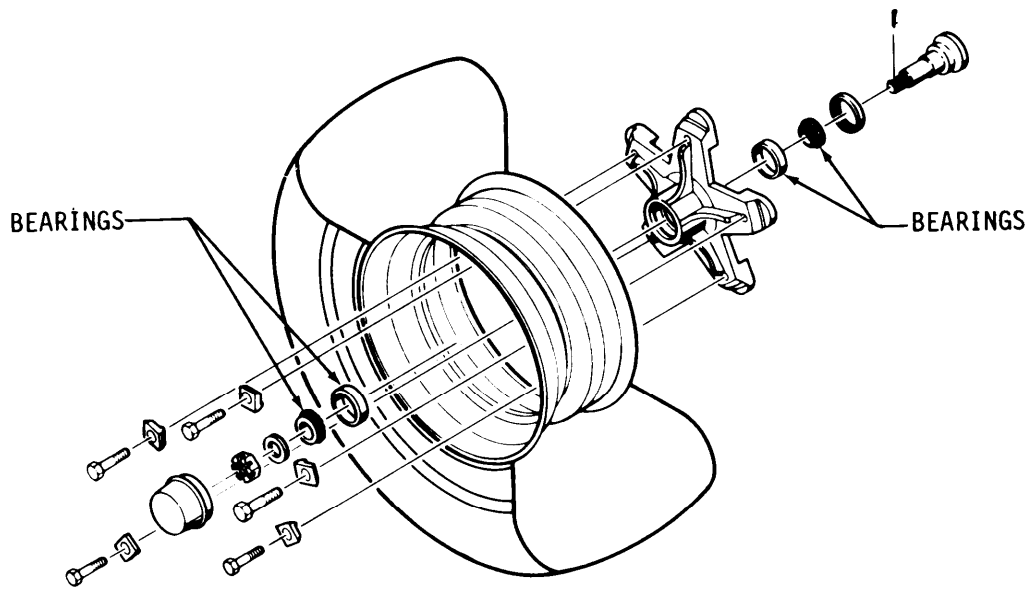

Figure 5-2. Hub Assembly - Lubrication

Table 5-1. Troubleshooting Guide

PROBLEM	PROBABLE CAUSE (S)	REMEDY
GRATING RATTLES WHILE TOWING	Clamp bracket(s) loose or unfastened.	Inspect and adjust or replace. (See para. 5.5.7.)
TOWBAR WILL NOT TIGHTEN SECURELY	Damaged T-lock. Pegs on T-lock are not aligned with proper holes.	Replace. Align the pegs with the holes. (See para. 4.1.1.)
RAMP DRAGS OR IS LOW ON ONE SIDE	Tire pressure too low. Tire flat. Low air spring pressure.	Check pressure with air gauge. Reinflate to 75-85 lbs. Remove, repair or replace and reassemble. (See para. 5.5.6.2.) Check pressure and inflate to 45-50 lbs.
TIRE WILL NOT HOLD AIR	Hole, cut, or bad valve.	Remove, repair or replace, and reassemble. (See para. 5.5.6.2.)
AIR SPRING WILL NOT HOLD AIR	Leak in spring. Bad valve.	Inspect then remove and repair or replace. (See para. 5.5.8.) Inspect then remove and replace if required.

Table 5-1. Troubleshooting Guide (Continued)

PROBLEM	PROBABLE CAUSE(S)	REMEDY
WHEEL ASSEMBLY WOBBLER OR IS GRINDING DURING TOWING	Wheel bearing is defective.	Inspect then remove bad bearing. (See para. 5.5.6.1.)
	Loose wheel rim bolts.	Inspect and tighten (torque with 85-90 ft lbs).
WHEEL WILL NOT TURN	Damaged bearing.	Replace defective bearing. (See para. 5.5.6.1.)
HYDRAULIC CYLINDER WILL NOT ELEVATE	Damaged or broken hydraulic lines.	Replace defective hoses. (See para. 5.5.9.3.)
	Plugged orifice.	Clean and rebuild pump. (See para. 5.5.9.1.)
	Oil reservoir not full.	Fill reservoir. (See para. 5.5.9.1.2.w.)
	Bad cylinder seal.	Replace seal. (See para. 5.5.9.1.) Rebuild pump.
PUMP FUNCTIONS ON LAST PORTION OF STROKE ONLY	Oil reservoir not full.	Fill reservoir. (See para. 5.5.9.1.2.w.)
	Inlet ball leaking.	Rebuild pump. (See para. 5.5.9.1.)
	Dirty inlet screen.	Clean screen and reservoir. (See para. 5.5.9.1.)
PUMP NOT BUILDING PRESSURE	Oil reservoir not full.	Fill reservoir. (See para. 5.5.9.1.2.w.)
	Inlet ball leaking.	Rebuild pump. (See para. 5.5.9.1.)
	Defective o-ring on selector valve spool.	Rebuild pump. (See para. 5.5.9.1.)
	Relief valve improperly set or blocked open.	Clean and adjust. Rebuild pump. (See para. 5.5.9.1.)
PUMP LEAKS BETWEEN BASE AND RESERVOIR	Defective o-ring on reservoir.	Replace o-ring. (See para. 5.5.9.1.)
RAMP DOES NOT GO ALL THE WAY DOWN WHEN PUMP CONTROL VALVE IS IN LOWER POSITION	Return orifice blocked.	Clean and replace orifice screw. (See para. 5.5.9.1.) Rebuild pump.
OIL LEAK AT HAND PUMP	Damaged seal.	Rebuild pump. (See para. 5.5.9.1.)
OIL LEAKS UNDERNEATH RAMP	Damaged hose.	Replace hose section. (See para. 5.5.9.1.)
RAMP ELEVATES UNEVENLY	Damaged cylinder.	Replace cylinder. (See para. 5.5.9.20)

Table 5-2. Inspection Guide

RAMP ASSEMBLY	INSPECT	PROBLEMS
Frame	Lift Rings	Mounting bolts loose.
	Reflectors	Broken or loose.
	Safety Chain Assembly	Mounting bolts loose.
		Connector link broken.
	Shackle pin loose or broken.	
	Main Frame	Broken or c r a c k e d weldments.
Undercarriage / Wheels	Grease Cap	Missing.
	Yoke	Broken or c r a c k e d weldman
	Clevis Pins	Cotter pins missing.
	Pivot Pins	Cotter pins missing.
	Grease Fittings	Grease fittings loose or missing.
	Tires	Low air pressure.
Hydraulic Assembly	Pump Mounting Bracket	Broken or c r a c k e d weldments.
		Loose or missing bolts.
	Lines	Leaking fluid.
	Pump	Fluid leaks.
	Lift Cylinders	Leaks.
	Hose Clamps	Broken or bent.

5.5 DISASSEMBLY, REPAIR OR REPLACEMENT, AND REASSEMBLY

5.5.1 Towbar (Fig. 5-3)

5.5.1.1 Disassembly

- a. Tap on the roll pin (2) with a hammer to remove it from T-lock (6).
- b. Remove T-lock handle (3) and washers (4 and 5) from T-lock (6).
- c. T-lock (6) can now be removed.
- d. Refer to the parts list to order replacement parts.

5.5.1.2 Reassembly

- a. Insert T-lock (6) through hole in towbar (1).

NOTE

- Ensure positioning block (7) of the towbar is placed downward
- b. Slide flat washer (5) and lock washer (4) over the end of T-lock (6).
- c. Thread lock handle (3) on T-lock (6):
- d. Tap roll pin (2) through T-lock (6) with a hammer.

5.5.2 Safety Chain Assembly (Fig. 5-4)

5.5.2.1 Disassembly

- a. Place a 3/4 inch box wrench on locknut (4).
- b. Place a 3/4 inch socket and ratchet over safety chain mounting bolt (3).

c. Loosen and remove mounting bolts (3) and locknuts (4).

d. The safety chain mounting plate assembly (2) can now be removed from frame bracket (1).

e. Refer to the parts list for replacement parts.

5.5.2.2 Reassembly

a. Insert mounting bolts (3) through the holes in mounting plate (2) and frame bracket (1).

b. Thread locknuts (4) onto the ends of bolts (3). Tighten by hand.

c. Place a 3/4 inch box wrench on locknuts (4) and a 3/4 inch socket and ratchet over bolts (3) and tighten securely.

5.5.3 Lift Ring Assembly (Fig. 5-4)

5.5.3.1 Disassembly

a. Place a 3/4 inch box wrench on locknut (7).

b. Place a 3/4 inch socket and ratchet over mounting bolt (6).

c. Loosen and remove mounting bolts (6) and locknuts (7).

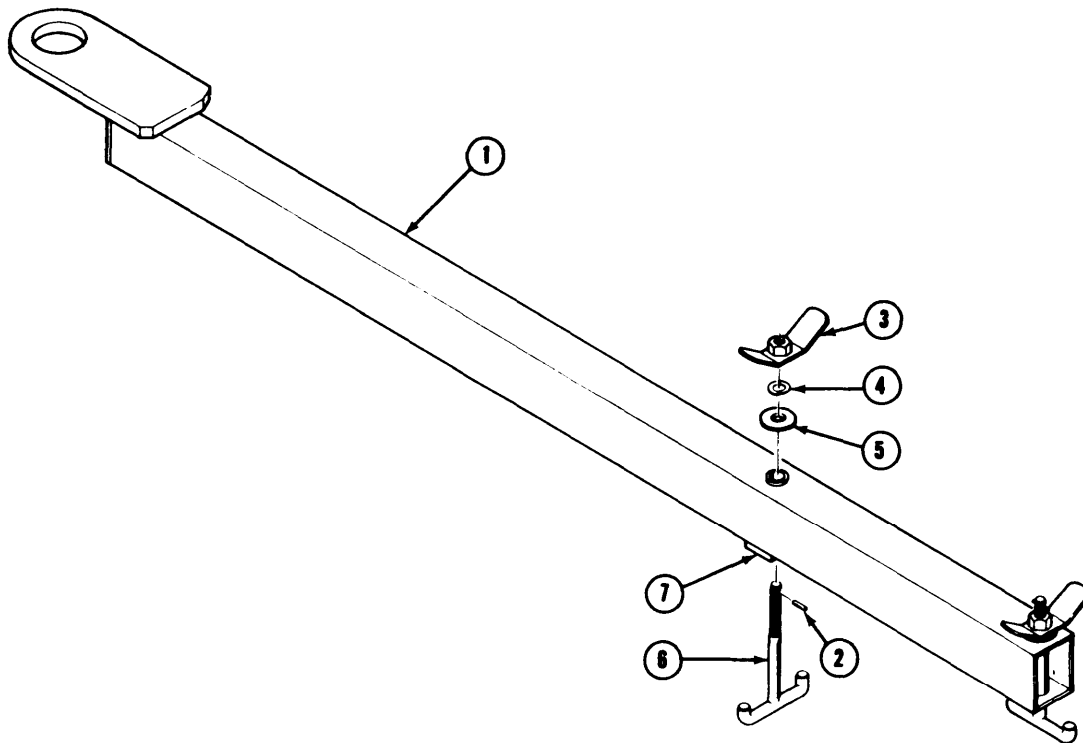

Figure 5-3. Towbar Assembly

d. The lift ring mounting plate assembly (5) can now be removed from frame bracket (8).

e. Refer to the parts list for replacement parts.

5.5.3.2 preassembly

a. Insert mounting bolts (6) through the holes in mounting plate (5) and frame bracket (8).

b. Thread locknuts (7) onto the ends of bolts (6). Tighten by hand.

c. Place a 3/4 inch box wrench on locknuts (7) and a 3/4 inch socket and ratchet over bolts (6) and tighten securely.

5.5.4 Reflector Assembly (Fig. 5-5)

5.5.4.1 Disassembly

a. Using a medium, flat tip screwdriver, loosen and remove pan head screw (2) from the center of reflector (1).

b. Refer to the parts list for replacement parts.

5.5.4.2 Reassembly

a. Insert pan head screw (2) through the center of reflector (1).

b. Thread screw (2) into frame.

c. Tighten screw (2) with a medium, flat tip screwdriver.

5.5.5 Undercarriage Assembly (Fig. 5-6)

5.5.5.1 Disassembly

a. Using the hydraulic pump, elevate the ramp enough to clear the wheels.

b. Support the elevated end with blocks.

WARNING

Secure the ground end of the ramp to prevent the ramp from sliding off the blocks.

c. Place the pump control valve in the LOWER position.

d. Remove cotter pins (10) from lower clevis pins (9) holding hydraulic lift cylinders (Fig. 5-6).

e. Slide clevis pins (9) out.

NOTE

The hydraulic cylinders will be left attached to the ramp frame.

f. Place a 3/4 inch box wrench over locknuts (3).

g. Place a 3/4 inch socket and ratchet over mounting bolts (2).

h. Loosen and remove locknuts (3) and bolts (2).

i. Swing hydraulic lift cylinders (1, Fig. 5-13) clear of the undercarriage assembly (Fig. 5-6) and pull the undercarriage from underneath the ramp.

NOTE

It is necessary to remove the undercarriage only when repairing a cracked or broken weld on the yoke assembly or when a damaged axle requires replacing the yoke assembly.

j. Loosen and remove grease fittings (7, Fig. 5-6) from pivot tube.

k. Remove cotter pins (6) from pivot pins (5).

l. Remove mounting blocks (1) from the ends of pivot pins (5).

m. Slide pivot pins (5) from pivot tubes and remove spacer washers (4).

WARNING

Place the undercarriage up on blocks high enough to allow the wheels to turn before proceeding.

n. Remove tire and rim (1 and 2, Fig. 5-7) and hub assembly (3) from axle by removing rim bolts (9) and rim clamps (10).

o. Refer to parts list for undercarriage replacement part number.

5.5.5.2 Reassembly

a. Install tire and rim (1 and 2, Fig. 5-7) and hub assembly (3) to axle by using rim clamps (10) and rim bolts (9).

b. Insert pivot pins (5, Fig. 5-6) through pivot tubes placing spacer washers (4) over the ends of pivot pins.

c. Slide mounting blocks (1) over the ends of pivot pins (5).

d. insert cotter pins (6) through the holes in the ends of pivot pins (5). Secure cotter pins.

e. Take the undercarriage off the blocks and place it into position under the ramp.

f. Align the holes in mounting blocks (1) with the holes in ramp frame.

g. Insert bolts (2) through the holes.

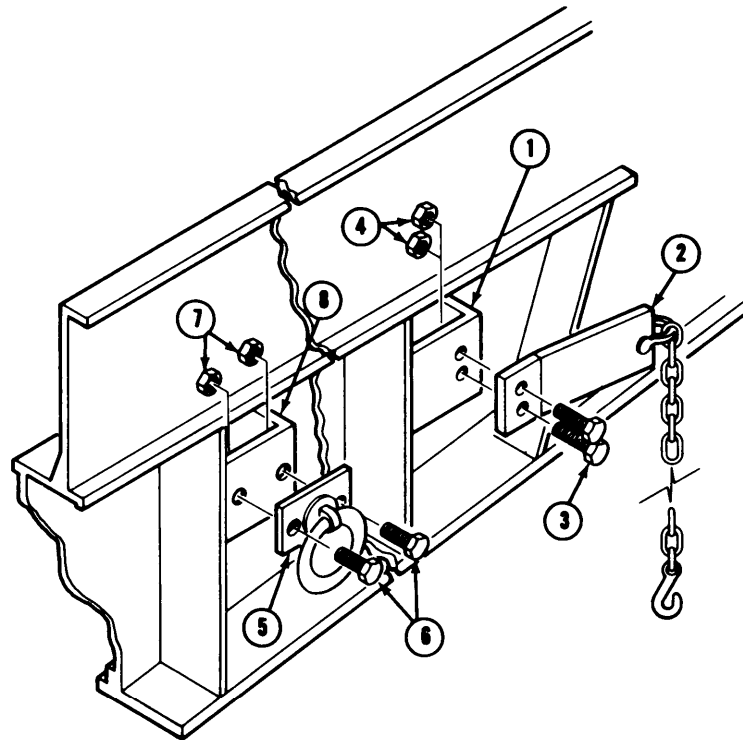

Figure 5-4. Frame Bracket Assembly

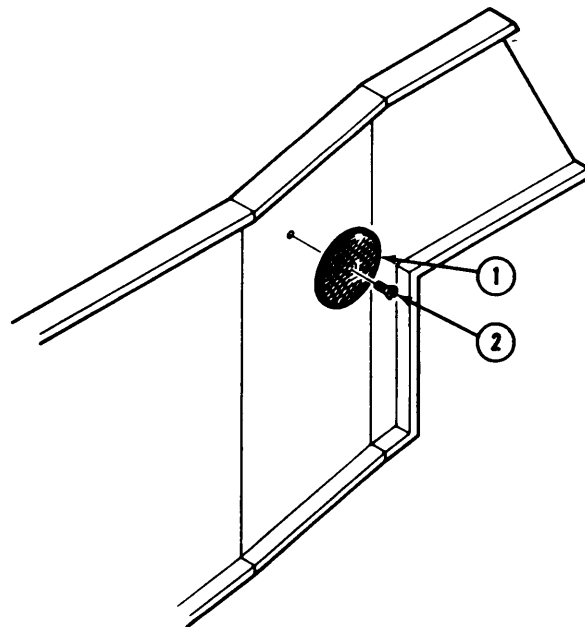

Figure 5-5. Reflector Assembly

h. Thread locknuts (3) onto bolts (2) and tighten by hand.

i. Use a 3/4 inch box wrench on locknuts (3) and a 3/4 inch socket and ratchet on bolts (2) to tighten securely.

j. Attach hydraulic lift cylinders (1, Fig. 5-13) to the undercarriage by aligning the mounting holes on the lower half of cylinder (2) with the holes in cylinder rod mounting brackets (3).

k. Slide lower clevis pins (9, Fig. 5-6) through cylinder rod mounting brackets (3, Fig. 5-13) and cylinder rod.

l. Insert cotter pins (10, Fig. 5-6) through the holes in the ends of clevis pins (9). Secure cotter pins.

5.5.6 Hub Assembly (Fig. 5-7)

5.5.6.1 Disassembly

a. Using the hydraulic pump, elevate the ramp enough to clear the wheels.

b. Support the elevated end with blocks.



Secure the ground end of the ramp to prevent the ramp from sliding off the blocks.

c. Place the pump control valve in the LOWER position.

d. Place blocks under the undercarriage to support the ramp when wheel and hub assemblies are removed.

e. Place a 3/4 inch socket and ratchet over rim bolt (9). Loosen and remove bolts and rim clamps (10).

f. Remove tire (1) and rim (2) as a unit.

g. Remove grease cap (8) from hub (3).

h. Remove cotter pin (7) from axle (6).

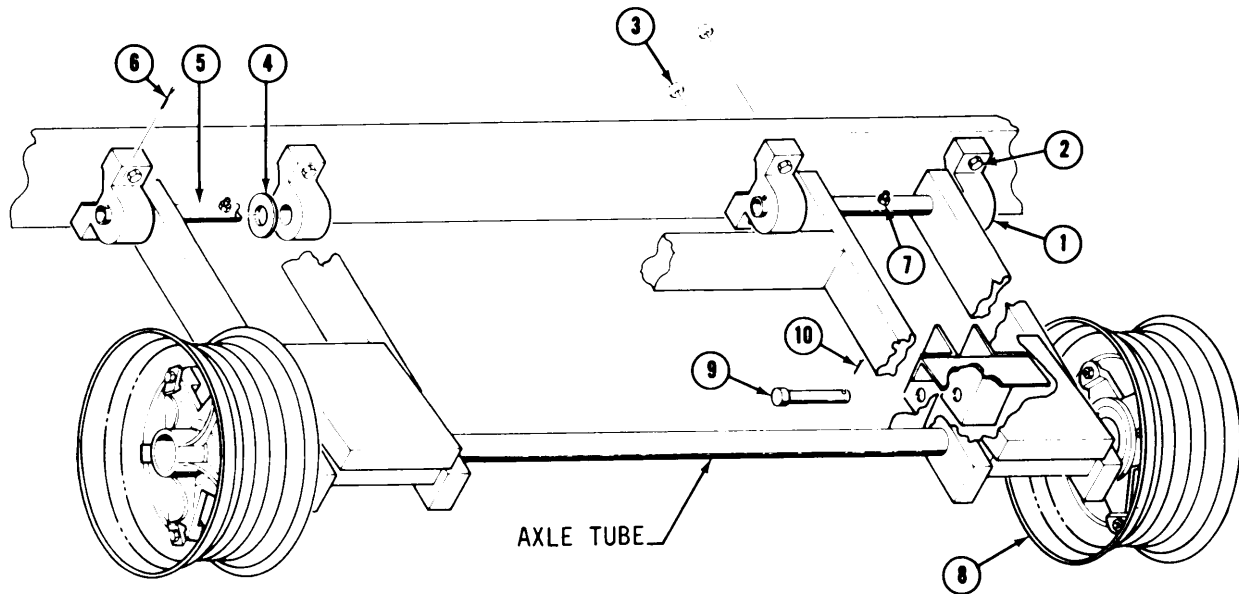

Figure 5-6. Undercarriage Assembly

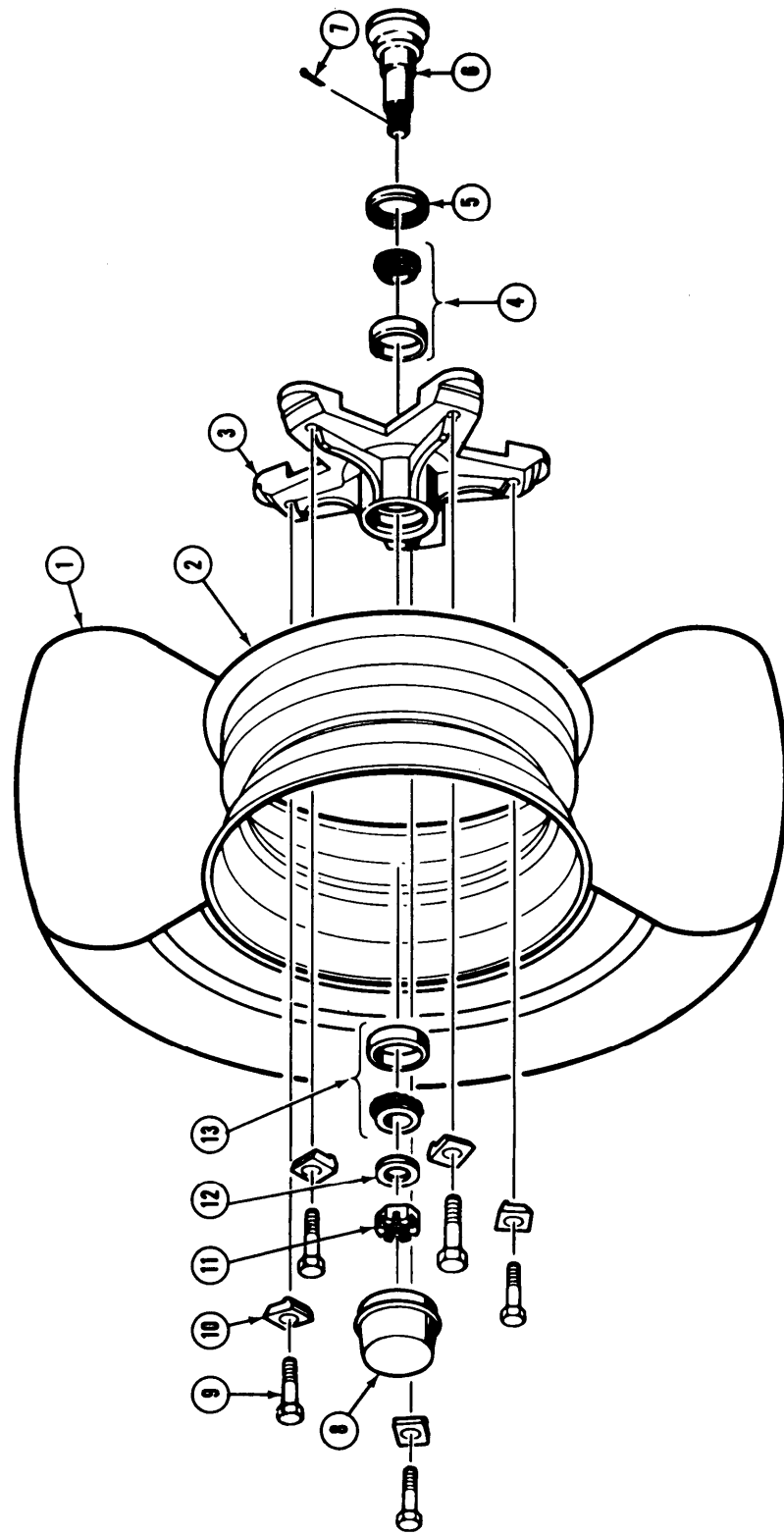

Figure 5-7. Hub Assembly

i. Remove spindle nut (11) and washer (12) from axle (6).

j. Pull hub (3) off axle (6).

k. Outer bearing assembly (13) will come off axle (6) when hub (3) is removed.



Inspect inner bearing assembly (4) contained in hub for damage. Do not remove unless replacement is required.

l. Remove inner bearing assembly (4), if required.

m. Remove seal (5).

n. Refer to the parts list for replacement parts.

5.5.6.2 Tire Repair and Replacement

a. Tire (1) can be removed from rim (2) using a conventional tire changer and can be repaired (if possible) with conventional rubber plugs or a commercial valve replacement.

b. Refer to the parts list for replacement parts.

5.5.6.3 Reassembly

a. Pack inner bearing assembly (4) with waterproof automotive grease, Military Specification MIL-G-10924, or equivalent.

b. Push inner bearing assembly (4) into hub (3) until firmly seated.

c. Press seal (5) into hub (3) until firmly seated.

d. Place hub (3) with inner bearing assembled onto axle (6).

e. Pack outer bearing assembly (13) with waterproof automotive grease, Military Specification MIL-G-10924, or equivalent.

f. Place outer bearing assembly (13) over axle (6) and push until firmly seated in hub (3).

g. Slide washer (12) over axle (6).

h. Thread spindle nut (11) onto axle (6) until snug against washer (12).

NOTE

Spindle nut (11) should be tight enough to prevent any play, or w o b b l e, in the hub assembly, but not so tight as to keep the hub from turning on the axle.

i. Ensure the hole in the end of axle (6) can be seen through the slots in spindle nut (11).

j. Insert cotter pin (7) through the hole in axle (6). Secure cotter pin.

k. Place grease cap (8) into hub (3).

l. Place tire (1) and rim (2) assembly in position on hub (3).

m. Insert rim bolts (9) through rim clamps (10) and thread bolts into hub (3).

n. Tighten all rim bolts (9) by hand.

o. Place a 3/4 inch socket and ratchet over any one of rim bolts (9) and tighten. Move the socket to the bolt directly across from the bolt just tightened and secure bolt. Continue this procedure until all rim bolts and clamps are securely fastened.

NOTE

The rim bolts may need tightening more than one time d u r i n g this procedure to obtain 85-90 ft lbs torque.

5.5.7 Grating (Fig. 5-8)

5.5.7.1 Disassembly

a. The grating can be removed from the ramp frame in sections. There are four sections which can be removed individually. The grating does not break down any further.

b. To remove a section of grating, remove all the clamps as necessary.

c. To remove the clamps, proceed as follows:

(1) Place a 1/2 inch socket with ratchet over clamp bolt (1).

(2) Place a 1/2 inch box wrench over locknut (4). Loosen and remove locknut.

(3) Remove washer (3) and pull clamp bolt (1) up to remove.

(4) Remove clamp (2) from grating surface.

(5) Remove the section of grating off the ramp frame.

(6) Refer to the parts list for replacement parts.

5.5.7.2 Reassembly

a. Lay a section of grating in place on the ramp frame. The grating will lay flat on the top of the I-beams.

b. Insert bolt (1) through clamp (2) and then through the grating and one of the holes in the I-beam. Ensure the clamp seats i t s e l f over the grating properly.

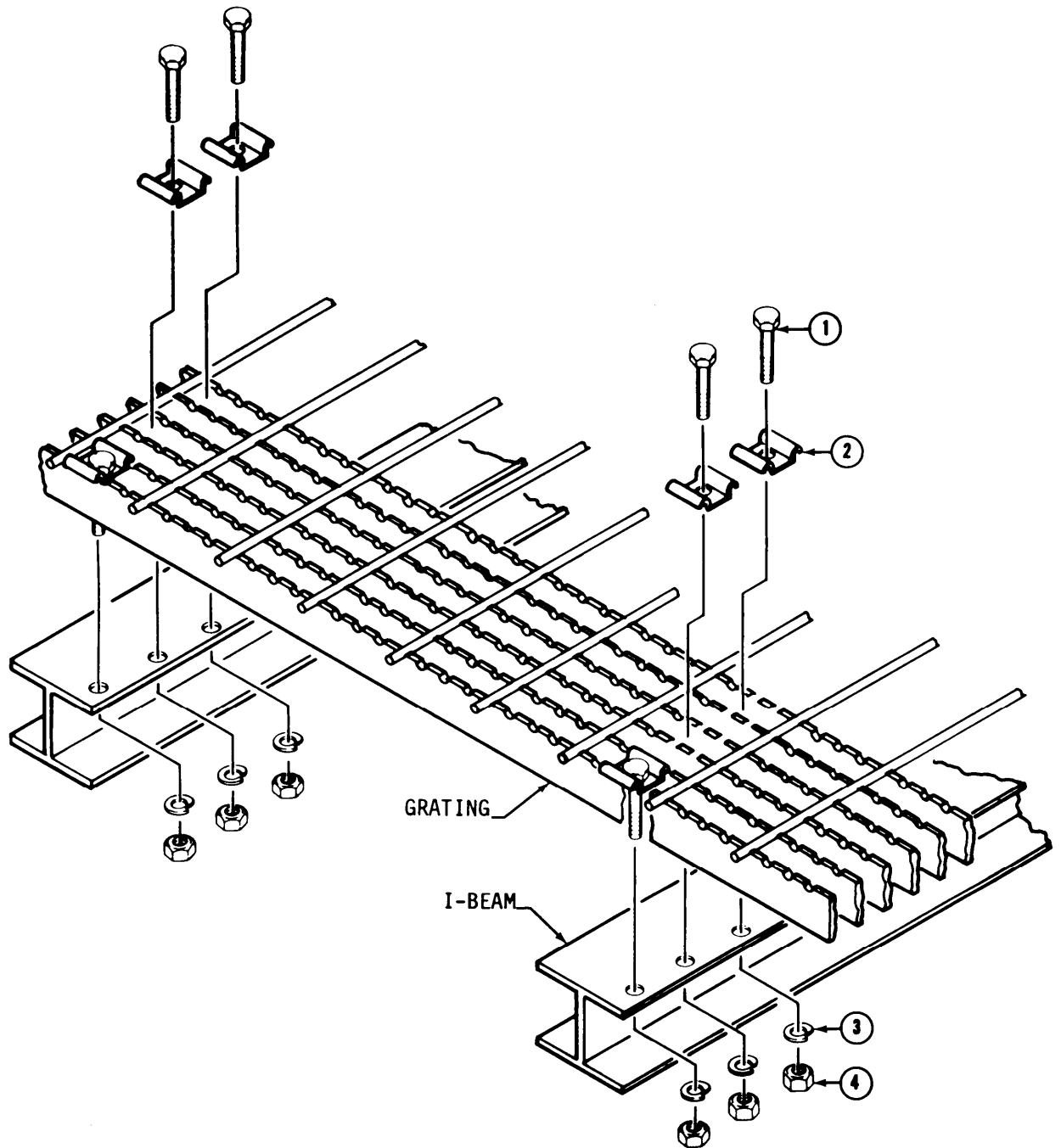

Figure 5-8. Grating and Clamps Assembly

- c. Place washer (3) over the end of bolt (1).
- d. Thread locknut (4) onto the end of bolt (1). Tighten by hand.
- e. Use a 1/2 inch socket with ratchet on bolt head (1) and a 1/2 inch box wrench on locknut (4) to tighten the assembly securely.
- f. Continue this procedure until all the holes in the I-beams are used, securing the grating in place.

5.5.8 Air Spring Assembly (Fig. 5-9)

5.5.8.1 Disassembly

- a. Place a 9/16 inch box wrench over locknut (4) and a 9/16 inch socket with ratchet over air spring mounting bracket bolt (3). Loosen and remove all four locknuts and bolts.
- b. The air spring assembly can now be removed from underneath the ramp.
- c. Place the 9/16 inch socket with ratchet over air spring mounting bolt (2). Loosen and remove both bolts.
- d. Remove air spring hanger (1) from air spring (5).
- e. Use a 9/16 inch open end wrench to remove valve stem (6).
- f. Refer to the parts list for replacement parts.

5.5.8.2 Reassembly

- a. Thread valve stem (6) into air spring (5) and secure using a 9/16 inch open end wrench.

NOTE

- Valve stem (6) should be in the upward position.
- b. Align the holes in air spring hanger (1) with the holes in the top of air spring (5).
- c. Insert air spring mounting bolts (2) through hager (1) and thread into air spring (5).
- d. Place a 9/16 inch socket with ratchet over bolts (2) and tighten securely.
- e. Align the four holes in air spring hanger (1) with the hanger mounting holes in the frame.
- f. Insert mounting bracket bolts (3) through the holes.
- g. Thread locknuts (4) onto the ends of bolts (3) and tighten by hand.
- h. Place a 9/16 inch box wrench over locknuts (4) and a 9/16 inch socket with ratchet over bolt heads (3) and tighten securely.

5.5.9 Hydraulic System (Figures 5-10 and 5-11)

5.5.9.1 Hydraulic Pump

5.5.9.1.1 Disassembly

- a. Place a 3/4 inch open end wrench over hydraulic hose coupling (9, Fig. 5-10). Disconnect hose from pump body (1, Fig. 5-11).
- b. Place a 9/16 inch socket and ratchet over pump mounting bolts (10, Fig. 5-10). Loosen and remove bolts.
- c. The hydraulic pump can now be removed from under the ramp.
- d. Insert a 3/16 inch allen wrench into screw head (4, Fig. 5-11). Loosen and remove four screws.

NOTE

When reservoir screws (4) are loosened the hydraulic fluid will begin to drain. Capture this fluid and discard properly.

- e. Remove reservoir (2) and o-ring (3).
- f. Straighten and remove cotter pin (38).
- g. Remove washer (39) and beam link pin (37) from beam (34).
- h. Remove wave washers (41).
- i. Pull up on beam (34) to extract plunger (44).

NOTE

Unless replacing the beam or plunger, these parts can be left attached to each other.

- j. Remove wiper (45), backup ring (46), and o-ring (47). O-ring can be pried out with a small screwdriver or pick.
- k. Remove cylinder (48), o-ring (49), backup ring (50), o-ring (51), and ball (52).
- l. Insert a 9/64 inch allen wrench into capscrew (28). Loosen and remove capscrew and washer (29).
- m. Pull up on and remove spool (7).
- n. Remove o-rings (8, 9, and 10) from spool (7).
- o. Insert a 1/8 inch allen wrench into orifice screw (11). Loosen and remove screw.
- p. Remove wiper (12).
- q. Insert a 1/8 inch allen wrench into the top of setscrew (5). Loosen until lever (6) can be extracted from spool (7).
- r. Remove breather plug (13).

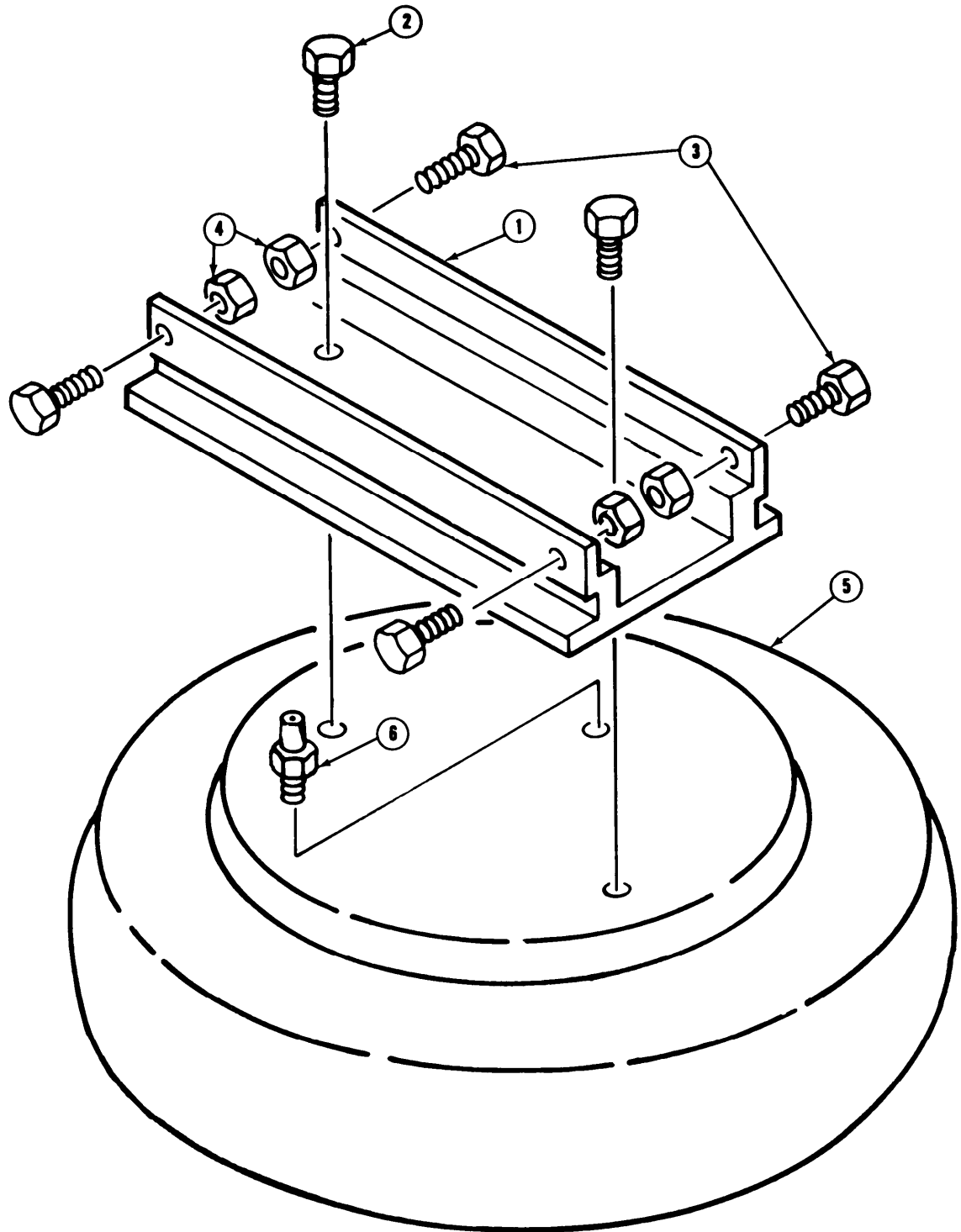

Figure 5-9. Air Spring Assembly

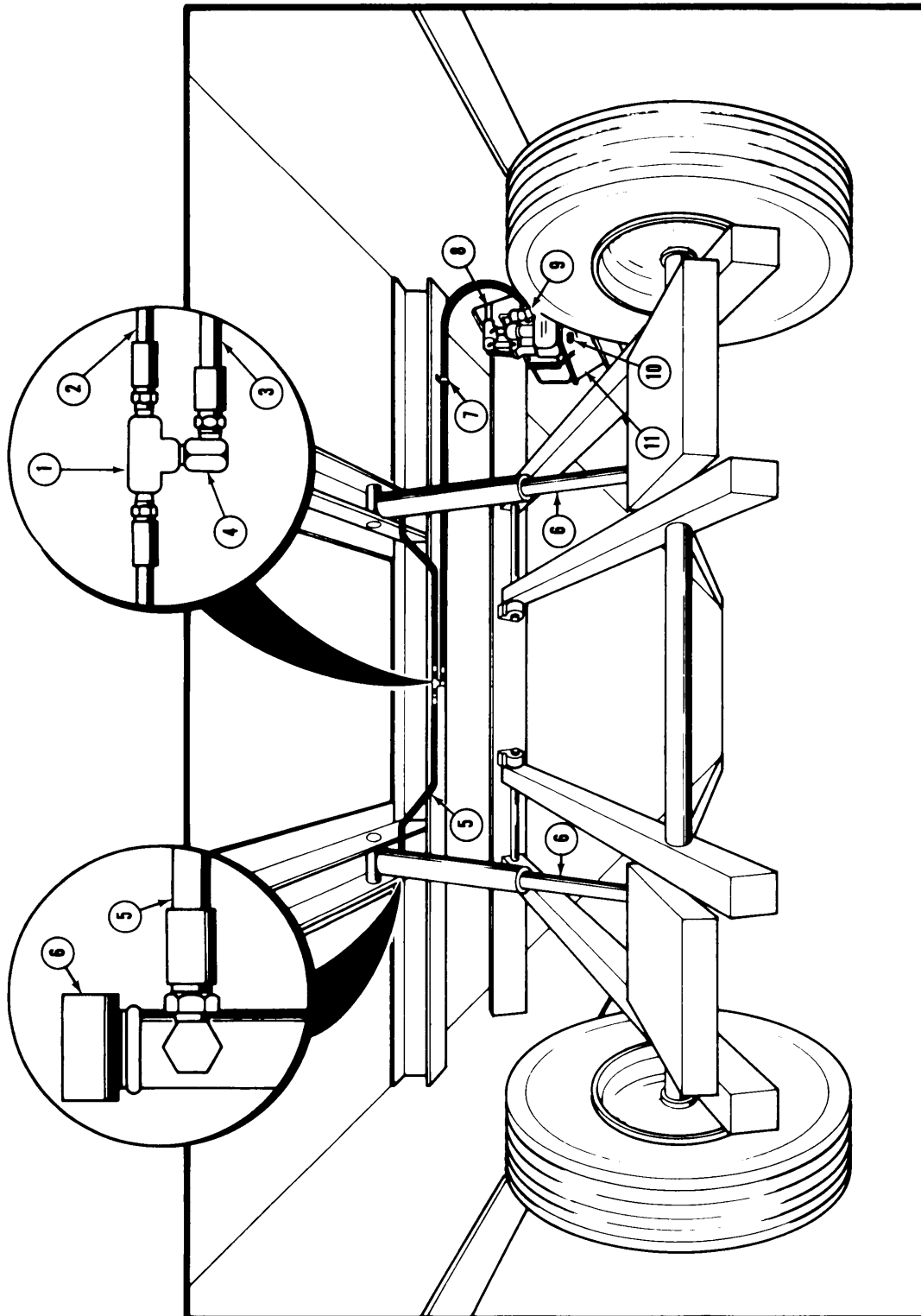

Figure 5-10. Hydraulic System - Location

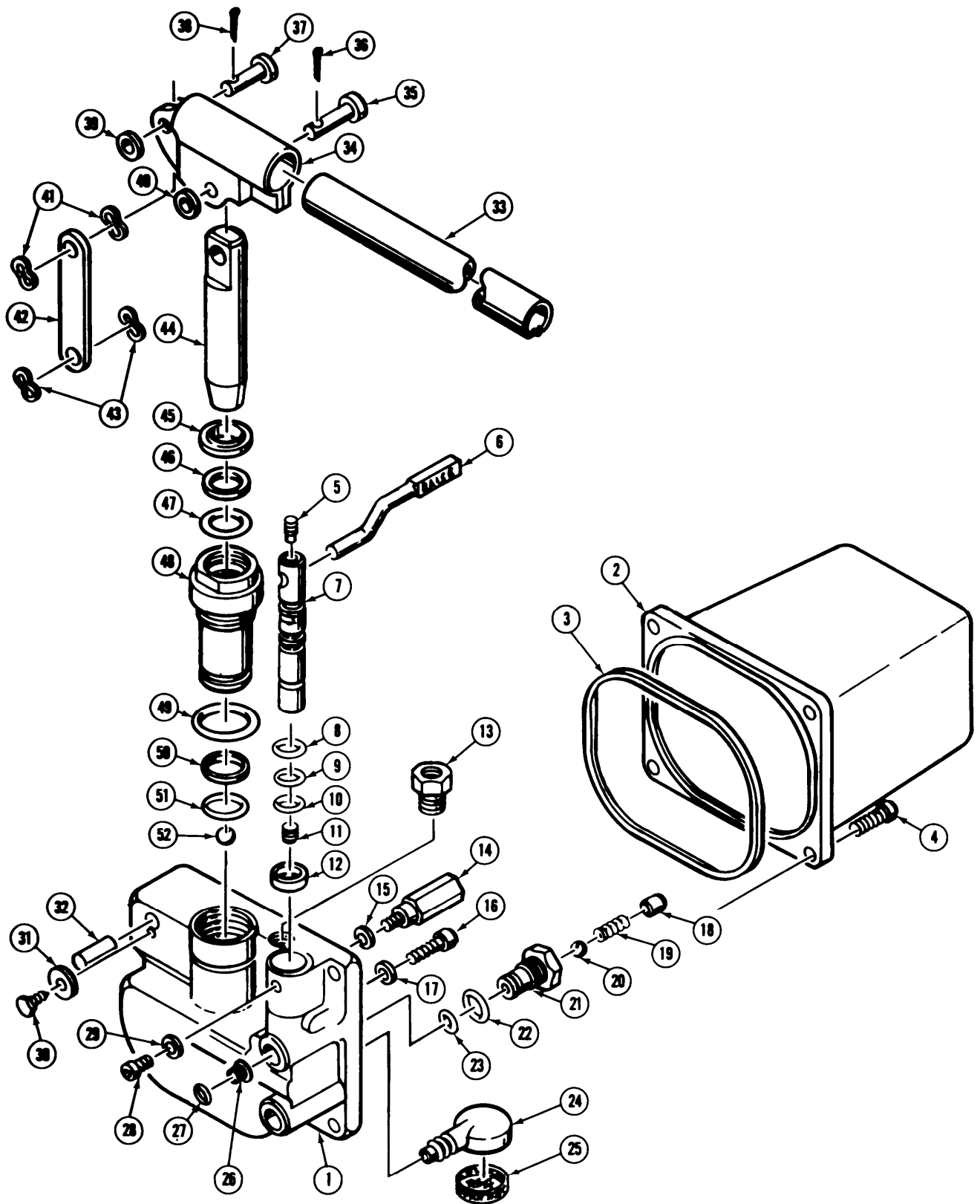

Figure 5-11. Hydraulic Pump Assembly

- s. Loosen relief valve (14) with a 3/8 inch box wrench. Remove relief valve and gasket (15).
- t. Insert a 5/64 inch allen wrench into plug (16). Loosen and remove plug and gasket (17).
- u. Remove retaining ring (27) and screen (26) from port.
- v. Use a 11/16 inch open end wrench to remove outlet seat (21) and o-rings (22 and 23).
- w. Insert a 5/36 inch allen wrench into plug (18). Loosen and remove plug, spring (19), and ball (20).
- x. Unthread inlet adapter (24) and remove screen (25).
- y. Place a 1/4 inch box wrench over self-tapping screw (30). Loosen and remove screw and washer (31).
- z. Remove base pin (32) from body (1).
- aa. Remove link (42) and wave washers (43).

5.5.9.1.2 Repair and Reassembly

NOTE

All gaskets, o-rings, balls, wipers, and washers used to repair the pump shall be found in the pump repair kit 3024, part no. 55500. Table 5-3 lists the parts found in the repair kit. Refer to the parts list for all other replacement parts.

- a. Replace o-ring (51, Fig. 5-11), backup ring (50), o-ring (49), and ball (52) to cylinder (48).
- b. Replace wiper (45), backup ring (46), and o-ring (47) in plunger bore. Backup ring will be placed rough side up.
- c. Coat o-rings with light grease and reinstall cylinder (48) in pump body (1) and plunger (44) into cylinder.
- d. Replace o-rings (8, 9, and 10) on spool (7).
- e. Install new wiper (12) in pump body (1). Place orifice screw (11) in body (1) and tighten with a 1/8 inch allen wrench.

Table 5-3. Pump Repair Kit 3024- P/N 55500

MAGLINE NO.	QUANTITY	NOMENCLATURE	VENDOR NO.
55516	2	Gasket	W222. 37
55518	1	Gasket	S3. 037
55521	1	O-ring	A8053. 503
55523	1	O-ring	B1906. 503
55524	1	O-ring	B1011. 403
55527	1	3/16" Ball	B1005. 016
55528	1	Wiper	A8064. 476
55529	1	Washer, Backup	B1115. 565
55530	1	O-ring	B1115. 903
55539	1	1/4" Ball	B1007. 016
55540	1	O-ring	B1912. 503
55541	2	O-ring	A8051. 503
55542	1	O-ring	A1008. 503
55543	1	Wiper	A1028. 476
55553	1	O-ring	B1019. 403
55552	1	Backup	B1019. 565

f. Coat o-rings (8, 9, and 10) on spool (7) with light grease and install in pump body (1).

g. Place lever (6) through hole in the top of spool (7) and install setscrew (5) into very top of spool. Tighten setscrew with a 1/8 inch allen wrench.

h. Insert capscrew (28) through washer (29) and install in pump body (1). Tighten screw with a 9/64 inch allen wrench.

i. Install breather plug (13) into top of body (1). Do not tighten plug.

j. Insert plug (16) through gasket (17) and install in pump body. Tighten plug with 4 ft lbs torque.

k. Replace gasket (15) over relief valve (14) and install to pump body. Tighten with 5 ft lbs torque.

l. Replace o-rings (23 and 22) on outlet seat (21). Replace ball (20) in outlet seat. Reinstall spring (19) and plug (18). Plug can be tightened with a 5/32 inch allen wrench.

m. Reinstall outlet seat (21) and torque to 19-21 ft lbs.

It is necessary, when reinstalling the outlet seat, to take care not to cut the o-rings.

n. Clean or replace screen (25) in inlet adapter (24) and install in pump body (1).

o. Replace gasket (3) in reservoir (2) and install reservoir to pump body (1) with four capscrews (4). Tighten cap screws with a 3/16 inch allen wrench.

p. Place link (42) into slot in the top of pump body (1) and place wave washers (43) in the same slot, one on each side of the link. Align the hole in the link with the hole in pump body and insert pin (32).

q. Insert screw (30) through washer (31) and install in pump body. Tighten screw with a 1/4 inch box wrench. Washer (31) will hold pin (32) in place.

r. Align holes in back of beam (34) with the hole in the top of link (42). Slide wave washers (41) in position on each side of the link.

s. Insert clevis pin (37) through the holes and place washer (39) over the end of clevis pin and push cotter pin (38) through hole in clevis pin. Secure cotter pin.

t. Place assembled pump back on mounting plate (11, Fig. 5-10).

u. Align the holes in mounting plate (11) with the mounting holes in the pump and insert pump mounting bolts (10). Tighten bolts with a 9/16 inch socket with ratchet.

v. Place screen (26, Fig. 5-11) and retaining ring (27) in the port on pump body. Place hydraulic hose coupling (9, Fig. 5-10) into the same hole and thread it into place by hand. Tighten the coupling in place with a 3/4 inch open end wrench.

w. Remove breather plug (13, Fig. 5-11) and fill reservoir with hydraulic fluid, Military Specification MIL-H-5606C, NSN-9150-00-252-6383, or equivalent. Reinstall breather plug and tighten with a 7/16 inch box wrench.

NOTE

Reservoir should be filled to the bottom of plug opening. The ramp should be in the lower position.

5.5.9.2 Hydraulic Cylinder (Fig. 5-12)

5.5.9.2.1 Disassembly

a. The hydraulic cylinder must be removed from the frame before it can be disassembled. To remove the cylinder, straighten and remove cotter pins (8 and 10) from clevis pins (7 and 9). Slide the clevis pins out of the frame (refer to Fig. 5-6).

b. Disconnect hose (5 or 2, Fig. 5-10) from cylinder (6).

c. The cylinder can now be removed and disassembled.

d. With the cylinder fully retracted, push a small screwdriver through port (2, Fig. 5-12). Using the screwdriver, unseat and shift lock ring (3) to the lower groove on rod (6).

e. Slide the body assembly (6) apart from barren assembly (1).

f. Remove lock ring (3), rod wiper (4), and rod seal (5).

NOTE

Replacement parts are included in the hydraulic cylinder repair kit no. 55559.

5.5.9.2.2 Reassembly

a. Replace seal (5) and wiper (4) over rod (6).

b. Replace lock ring (3) over rod (6). Do not seat the lock ring in the upper groove.

c. Insert rod (6) into barrel (1) to the fully collapsed position.

d. Push lock ring (3) until it seats into place on rod (6) in upper groove.

e. Place the barrel assembly in place in the top hydraulic cylinder bracket. Align the holes and insert clevis pin (9) through the holes. Insert cotter pin (10) through the hole at the end of the clevis pin.

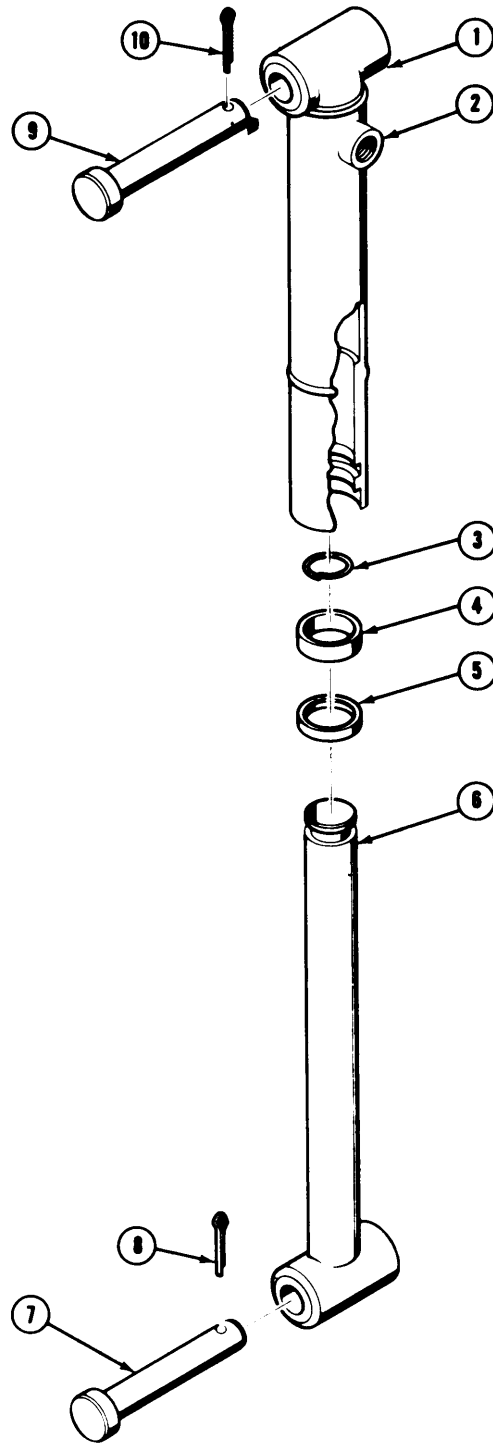

Figure 5-12. Hydraulic Lift Cylinder Exploded View

f. Align the hole in rod mount (2, Fig. 5-13) with lower cylinder bracket (3). Insert clevis pin (4) through the bracket and rod. Push cotter pin (5) through the hole in clevis pin. Secure cotter pins (8 and 10, Fig. 5-12).

g. Reassemble hydraulic hose fitting to extend port (2) on the cylinder.

5.5.9.3 Hydraulic Lines (Fig. 5-14)

5.5.9.3.1 Disassembly

- a. Extract rivets (8) from hose clamps (7).
- b. Disconnect 45 inch hose (5) from straight adapter union (6) on hydraulic pump and from 90° adapter (4).
- c. Disconnect 90° adapter (4) from female tee (2).
- d. Disconnect 27 inch hoses (1 and 3) from 90° adapter (4) in lift cylinder extend ports (2, Fig. 5-12) and female tee (2, Fig. 5-14).
- e. Disconnect 90° adapter (4) from lift cylinder.

f. Refer to the parts list for replacement parts. Rivets (8) will be replaced with a small slotted round head screw and hex nut (9).

5.5.9.3.2 Reassembly

- a. Connect 27 inch hoses (1 and 3) to female tee (2).
- b. Connect 90° adapter (4) to female tee (2).
- c. Connect 45 inch hose (5) to 90° adapter (4).
- d. Connect straight adapter union (6) to the hydraulic port.
- e. Connect the free end of hose (5) to straight adapter union (6) on the pump.
- f. Put hose clamps (7) back in place on the I-beam (Fig. 5-10). Secure the clamps with 1/4 NC x 1" slotted round head machine screws and hex nuts (9, Fig. 5-14).
- g. Connect 90° adapter (4) to cylinder ports.
- h. Connect the free ends of hoses (1 and 3) to the 90° adapters on the hydraulic cylinder.

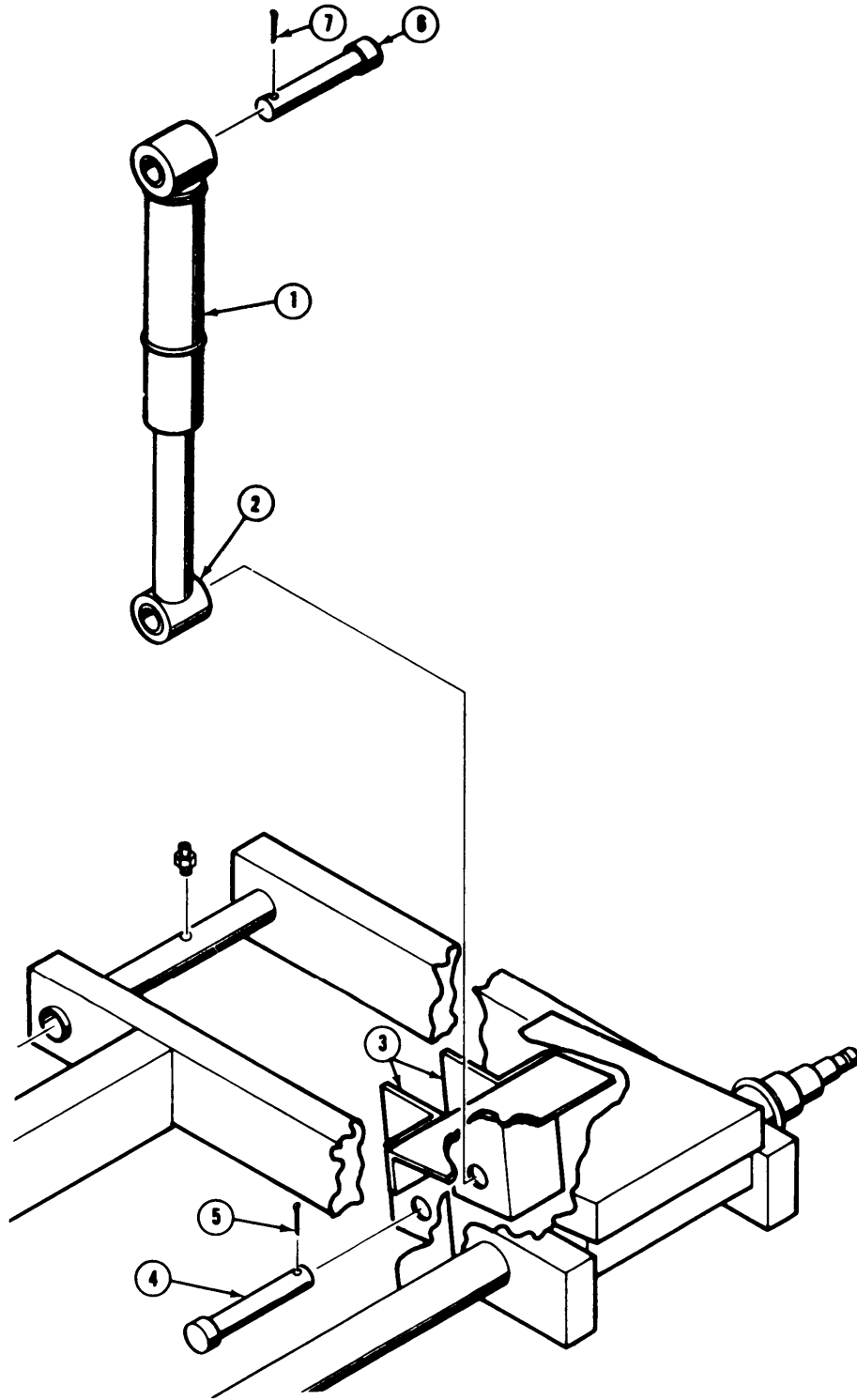

Figure 5-13. Hydraulic Lift Cylinder Assembly

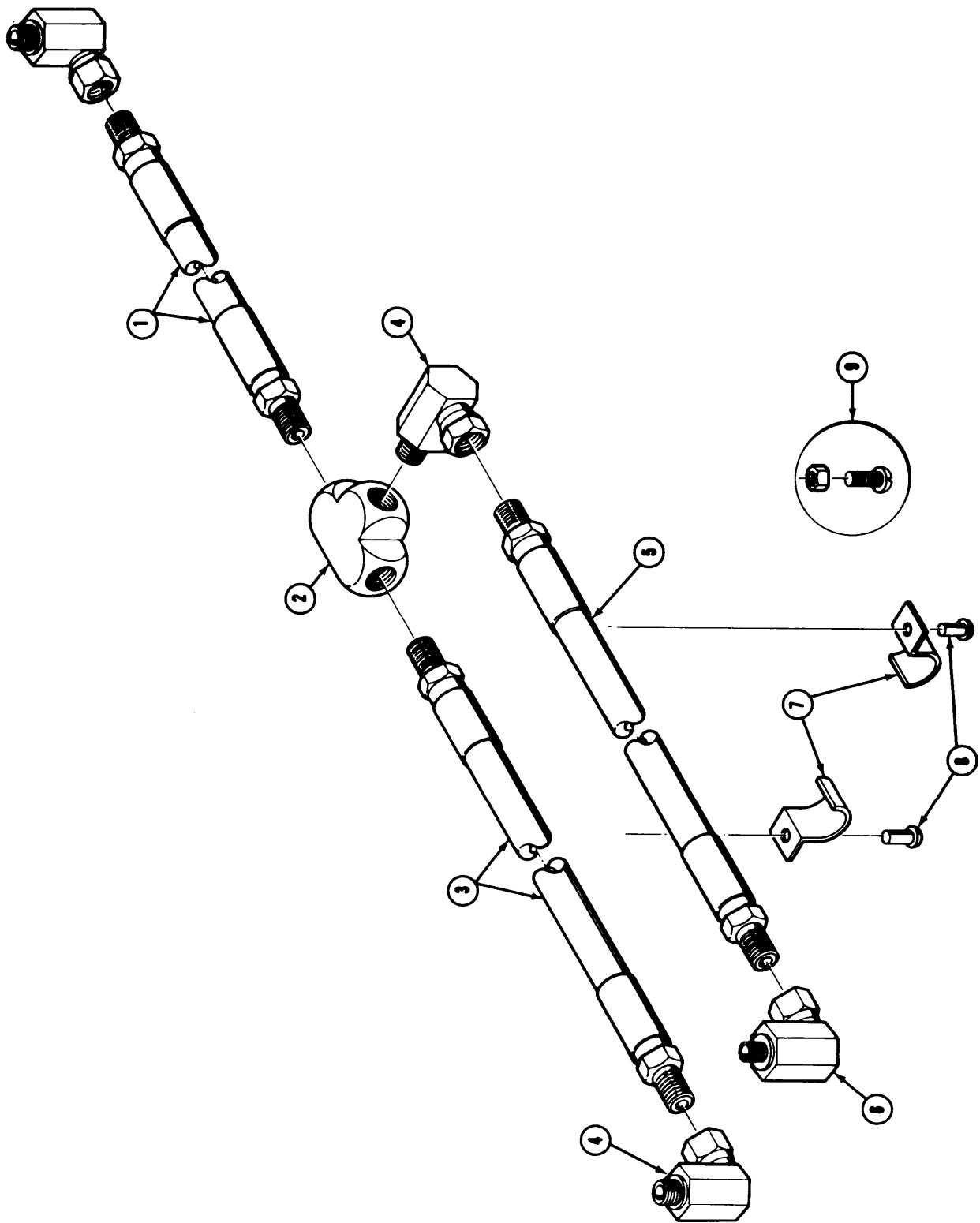

Figure 5-14. Hydraulic Lines

SECTION VI

ILLUSTRATED PARTS

6. INTRODUCTION

6.1 This Illustrated Parts List is comprised of a Numerical Index and a Group Assembly Parts List covering the Mobile Loading Ramp, Model Number MDS-16-92-36-6F-AS-12C.

6.1.1 Numerical Index

a. The Numerical Index is a complete alpha-numerical listing of all part numbers appearing in the Group Assembly Parts List.

b. When a listing in the Numerical Index is followed by the notation “(See -----)”, find the referenced number in the PART NUMBER column of the Numerical Index.

c. The total quantity of the part number is shown in the QUANTITY column.

6.1.2 Group Assembly Parts List

a. The Group Assembly Parts List indexes and illustrates all assemblies and detail parts in sections dealing separately with the Mobile Loading Ramp. Each section is prefaced by an exploded view which illustrates the parts listed in that section.

b. Parts are listed in the order of disassembly with attaching parts following the part or parts attached.

c. To use the parts list:

(1) Determine the part or assembly to be serviced or replaced and what section of the ramp the part or assembly is found.

(2) Locate the corresponding drawing in the list of illustrations, para. 6.2. Refer to the drawing and locate the part or assembly in the drawing.

(3) Match the callout number in the drawing with the number in the first column (FIG. AND ITEM NO.) of the parts list immediately following the drawing.

(4) Locate the part number of the subject part in the second column (PART NUMBER). This column contains the Magline part number.

(5) Where parts are supplied by a manufacturer other than Magline, the manufacturer's part number is shown parenthetically in the NOMENCLATURE column. The part number is followed by the Federal Supply Code for Manufacturers (FSCM) number, as published in Cataloging Handbook H4-1. See Manufacturers' Code List, para. 6.3, to determine manufacturer's name and address.

(6) The abbreviation "COML" in the NOMENCLATURE column denotes a part that can be procured from any commercial source.

(7) The fourth column (QUANTITY) shows the required number of the part or subassembly.

6.2 PARTS LIST ILLUSTRATIONS

Figure No.		Page No.
6-1	Ramp and Attaching Parts . .	6-4
6-2	Attaching Parts Assemblies .	6-6
6-3	Grating/Clamp Assembly . .	6-8
6-4	Towbar	6-10
6-5	Suspension, Yoke, Wheels, Tires	6-12
6-6	Hydraulic Pump	6-14
6-7	Hydraulic Lift Cylinders . . .	6-16
6-8	Hydraulic Lines and Fittings .	6-18

6.3 MANUFACTURERS' CODE LIST

FSCM NO.	Manufacturer's Name and Address
15460	Dexter Axle Co. Inc. P. O. Box 250 222 Collins Road Elkhart, IN 46515
26278	Lantex Hydraulics Inc, P. O. Box 340 600 Beltline Road Lancaster, TX 75146
26953	Power Packer Inc. 16901 W. Glendale New Berlin, WI 53151
27783	Schrader Automotive Products A Div. of Scovill Inc. P.O. Box 586 Dickson, TN 37055
73842	Goodyear Tire Company 1144 E. Market Street Akron, OH 44316
83205	Magline Inc. 503 S. Mercer Street Pinconning, MI 48650
96652	Rein Leitzke Inc. P. O. Box 305 Hustisford, WI 53034

6.4 NUMERICAL INDEX

PART NUMBER	FIG. & ITEM NO.	QUANTITY	PART NUMBER	FIG. & ITEM NO.	QUANTITY
A1014.245	(SEE 55542)	A1008.503	15-2	(SEE 19056)	
A1028.476	(SEE 55525)		15800X145F	6-5 21	2
A8000.042	(SEE 55543)		18012	6-5 23	2
A8008.108	(SEE 55551)		18013	6-5 24	2
A8008.108	(SEE 55538)		18026	6-5 27	2
A8008.108	(SEE 55538)		18046	6-5 17	2
A8008.108	(SEE 55538)		18046	6-5 17	2
A8015.049	(SEE 55545)		18047	6-5 19	2
A8017.028	(SEE 55555)		18048	6-5 18	2
A8019.060	(SEE 55531)		19029	6-5 22	2
A8021.018	(SEE 55520)		19047	6-5 6	2
A8023.108	(SEE 55537)		19048	6-5 26	2
A8032.061	(SEE 55532)		19049	6-5 25	2
A8033.061	(SEE 55535)		19055	6-5 30	10
A8037.062	(SEE 55533)		19056	6-5 29	7
A8040.018	(SEE 55546)		19060	6-5	2
A8040.027	(SEE 55548)		19061	6-5 5	2
A8041.157	(SEE 55547)		21-1	(SEE 18026)	
A8042.038	(SEE 55519)		25034	6-5 28	2
A8051.503	(SEE 55541)		310249	6-3 2	31
A8053.503	(SEE 55521)		310800	6-1 1	1
A8064.476	(SEE 55528)		310801	6-1 7	1
A8079.108	(SEE 55554)		310802	6-4	1
A8115.061	(SEE 55536)		310805	6-1 5	2
A8126.190	(SEE 55513)			6-2	
A8160.110	(SEE 55526)		310806	6-2 1	2
A8208.040	(SEE 55514)		310807	6-4 1	1
A8581.900	(SEE 55517)		310813	6-4 6	2
A9079.900	(SEE 55550)		310816	6-4 3	2
A9160.900	(SEE 55544)		310818	6-5	1
B1005.016	(SEE 55527)		310819	6-5 14	1
B1005.028	(SEE 55522)		310828	6-5 9	4
B1007.016	(SEE 55539)		310829	6-5 1	2
B1011.403	(SEE 55524)		310830	6-5 8	2
B1016.058	(SEE 55534)		310831	6-1 6	4
B1019.403	(SEE 55553)			6-2 8	
B1019.565	(SEE 55552)		310832	6-6 33	1
B1115.565	(SEE 55529)		5-27	(SEE 19049)	
B1115.903	(SEE 55530)		51087	(SEE 55561)	
B1322.028	(SEE 55515)		51234	(SEE 55560)	
B1906.503	(SEE 55523)		51727	(SEE 55558)	
B1912.503	(SEE 55540)		5386-02	(SEE 55556)	
B8035.617	(SEE 55511)		5386-18	(SEE 55557)	
B8338.030	(SEE 55512)		55500	6-6	1
C8115.025	(SEE 55505)		55501	6-6	1
D8141.190	(SEE 55510)		55502	6-8 5	1
HP3004-41-14	(SEE 55501)		55503	6-8 1	2
LM67010	(SEE 18013)			6-8 3	
LM67048	(SEE 18012)		55504	6-5 15	2
L68111	(SEE 18047)			6-7	
L68149	(SEE 18048)		55505	6-6 2	1
S3.037	(SEE 55518)		55506	6-8 6	1
TR-416	(SEE 19029)		55507	6-8 4	3
T-600	(SEE 12145X60)		55508	6-8 2	1
W222.37	(SEE 55516)		55510	6-6 1	1
1B12-306	(SEE 19061)		55511	6-6 7	1
10-40	(SEE 18046)		55512	6-6 48	1
12145X60	6-5 20	2	55513	6-6 21	1
12800X145F60	6-5	2	55514	6-6 44	1
1498P-8	(SEE 19047)		55515	6-6 18	1

PART NUMBER	FIG. & ITEM NO.	QUANTITY	PART NUMBER	FIG. & ITEM NO.	QUANTITY
	6-6 17	55516	55557	6-7 5	2
	6-6 28		55558	6-7 2	2
	6-6 14	55517	55559	6-7	1
55518	6-6 15	1	55560	6-7 4	2
55519	6-6 24	1	55561	6-7 3	2
55520	6-6 25	1	6-1	(SEE 19048)	
55521	6-6 3	1	62029	6-1 4	4
55522	6-6 4	4		6-2 11	
55523	6-6 22	1	7-36	(SEE 19055)	
55524	6-6 23	1	76307	6-1 2	2
55525	6-6 16	1		6-3 1	
55526	6-6 19	1	76308	6-1 3	2
55527	6-6 20	1		6-3	
55528	6-6 45	1	8-223-4	(SEE 25034)	
55529	6-6 46	1	8X14.5LRF	(SEE 15800X145F)	
55530	6-6 47	1	80001	6-8	2
55531	6-6 34	1	80018	6-3 3	31
55532	6-6 35	1	80023	6-5 3	8
55533	6-6 42	1	80025	6-5 2	4
55534	6-6 36	2	80027	6-2 9	8
	6-6 38		80048	6-2 6	4
55535	6-6 37	1	80050	6-5 10	8
55536	6-6 32	1	80286	6-2 12	4
55537	6-6 39	2	80601	6-8	2
	6-6 40		80602	6-3 5	31
55538	6-6 41	4	80603	6-2 10	16
	6-6 43			6-5 4	
55539	6-6 52	1	80606	6-2 7	12
55540	6-6 51	1		6-5 11	
55541	6-6 9	2	80701	6-3 4	31
	6-6 10		80708	6-4 5	2
55542	6-6 8	1	80710	6-5 12	4
55543	6-6 12	1	80764	6-4 4	2
55544	6-6 11	1	81006	6-8 8	2
55545	6-6 27	1	81026	6-8 7	2
55546	6-6 26	1	81049	6-5 13	2
55547	6-6 6	1	81081	6-5 7	6
55548	6-6 5	1	81083	6-5 31	2
55550	6-6 13	1	81087	6-5 16	4
55551	6-6 29	1	81127	6-4 2	2
55552	6-6 50	1	83026	6-2 5	2
55553	6-6 49	1	83027	6-2 4	2
55554	6-6 31	1	83029	6-2 2	2
55555	6-6 30	1	83030	6-2 3	2
55556	6-7 1	2			

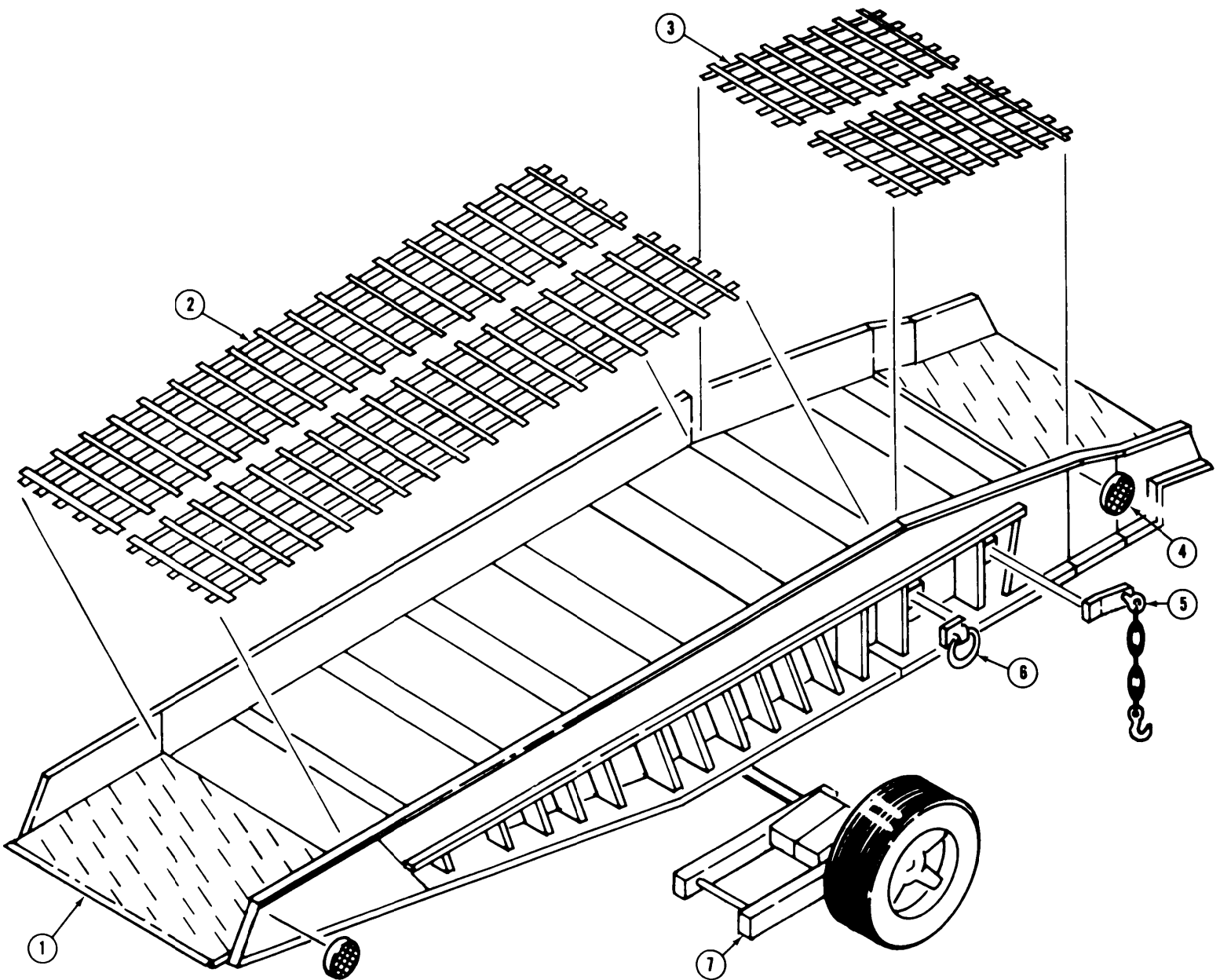

Figure 6-1. Ramp and Attaching Parts

6.5 GROUP ASSEMBLY PARTS LIST

FIG. & ITEM NO.	PART NUMBER	1	2	3	4	5	NOMENCLATURE	QTY
6-1							RAMP ASSEMBLY	1
1	310800						.FRAME WELDMENT	1
2	76307						.GRATING, 39 3/8 X 310 (SEE FIG. 6-3 FOR DETAIL BREAKDOWN)	REF
3	76308						.GRATING, 39 3/8 X 47 3/4 (SEE FIG. 6-3 FOR DETAIL BREAKDOWN)	REF
4	62029						.REFLECTOR (SEE FIG. 6-2 FOR DETAIL BREAKDOWN)	REF
5	310805						.SAFETY CHAIN ASSEMBLY (SEE FIG. 6-2 FOR DETAIL BREAKDOWN)	REF
6	310831						.RING, LIFT (SEE FIG. 6-2 FOR DETAIL BREAKDOWN)	REF
7	310801						.UNDERCARRIAGE ASSEMBLY (SEE FIG. 6-5 FOR DETAIL BREAKDOWN)	1

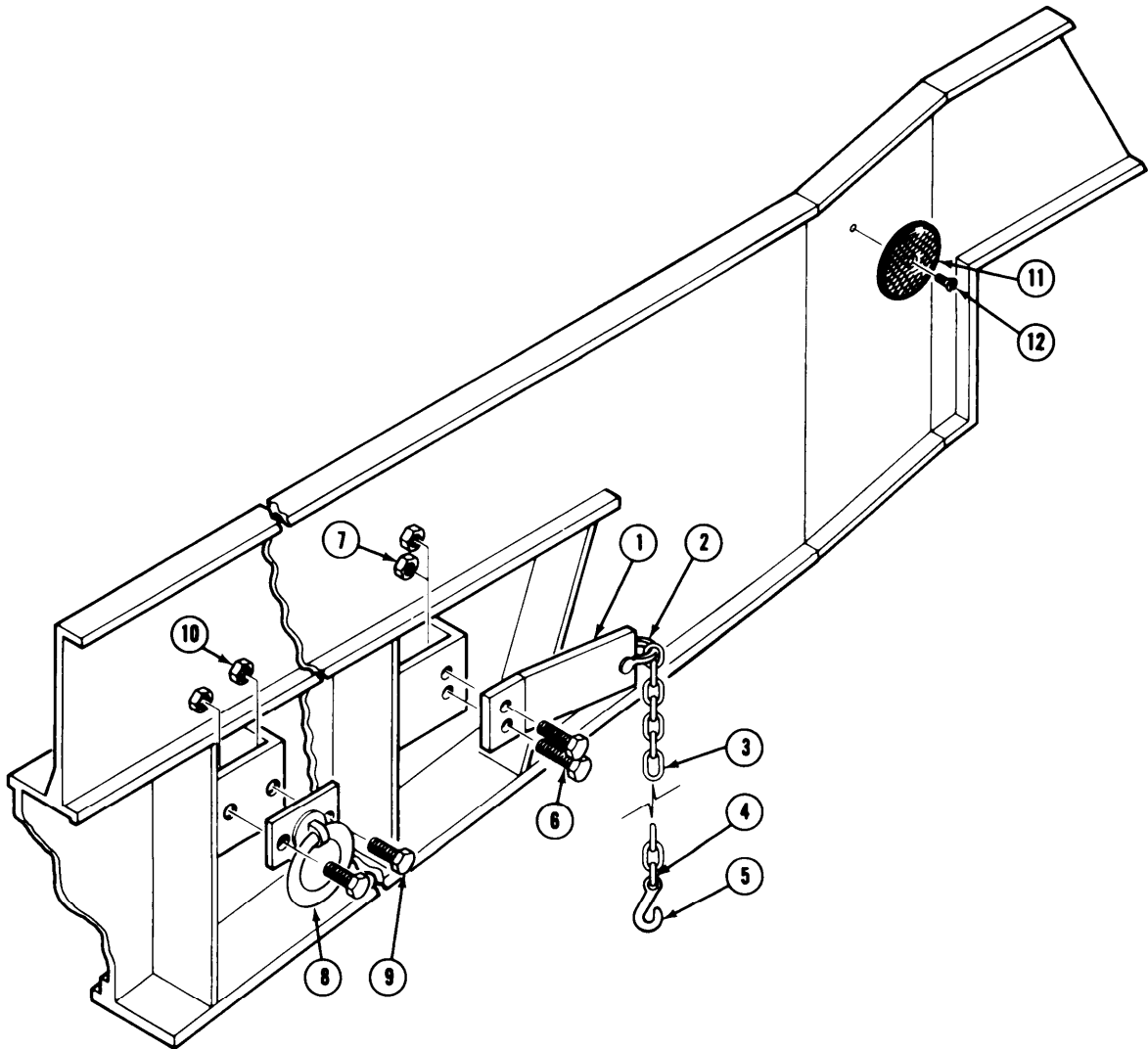

Figure 6-2. Attaching Parts Assemblies

FIG. & ITEM NO.	PART NUMBER	1	2	3	4	5	NOMENCLATURE	QTY
6-2							FRAME	1
	310805						.SAFETY CHAIN ASSEMBLY	2
1	310806						..PLATE, MOUNTING	2
2	83029						..SHACKLE/PIN, 1/4"	2
3	83030						..CHAIN, 1/4" X 8 FT	2
4	83027						..LINK, CONNECTING, 1/4"	2
5	83026						..HOOK, EYE-GRAB	2
6	80048						..CAPSCREW, HEX HD., 1/2-13 X 1 1/2	4
7	80606						..LOCKNUT, HEX, 1/2-13 "COML"	4
							.LIFT RING ASSEMBLY	2
8	310831						..RING, LIFT/TIE DOWN	4
9	80027						..CAPSCREW, HEX HD., 3/8-16 X 1 1/2	8
10	80603						..LOCKNUT, HEX, 3/8-16 "COML"	8
							..REFLECTOR ASSEMBLY	4
11	62029						..REFLECTOR	4
12	80286						..SCREW, PAN HD., #10 X 5/8	4

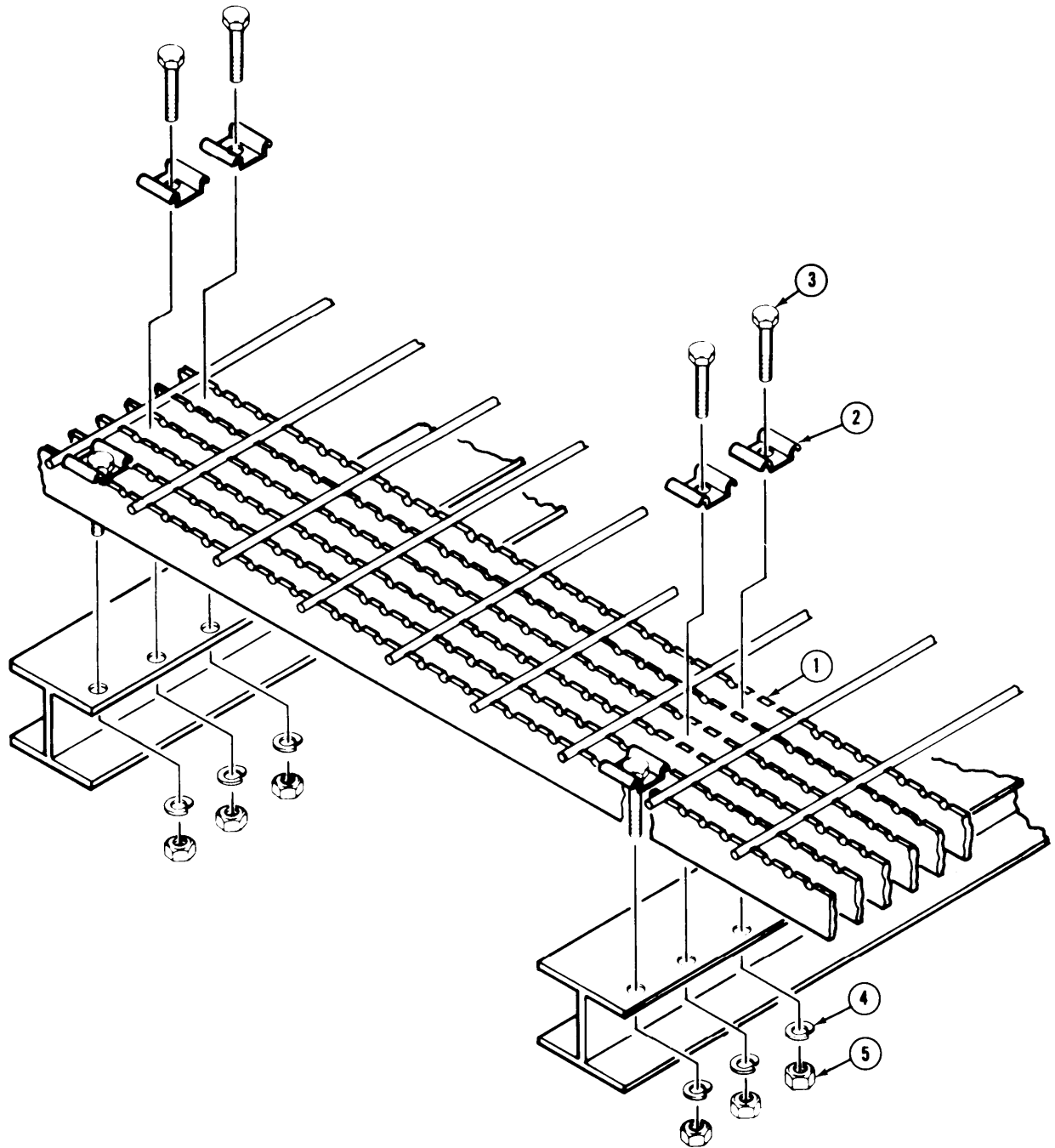

Figure 6-3. Grating/Clamp Assembly

FIG. & ITEM NO.	PART NUMBER	1	2	3	4	5	NOMENCLATURE	QTY
6-3							GRATING/CLAMP ASSEMBLY	1
1	76307						.GRATING, 39 3/8 X 310	2
	76308						.GRATING, 39 3/8 X 47 3/4	2
2	310249						.CLAMP, GRATING	31
3	80018						.CAPSCREW, HEX HD., 5/16-18 X 2 1/8 "COML"	31
4	80701						.WASHER "COML"	31
5	80602						.LOCKNUT, HEX, 5/16-18 "COML"	31

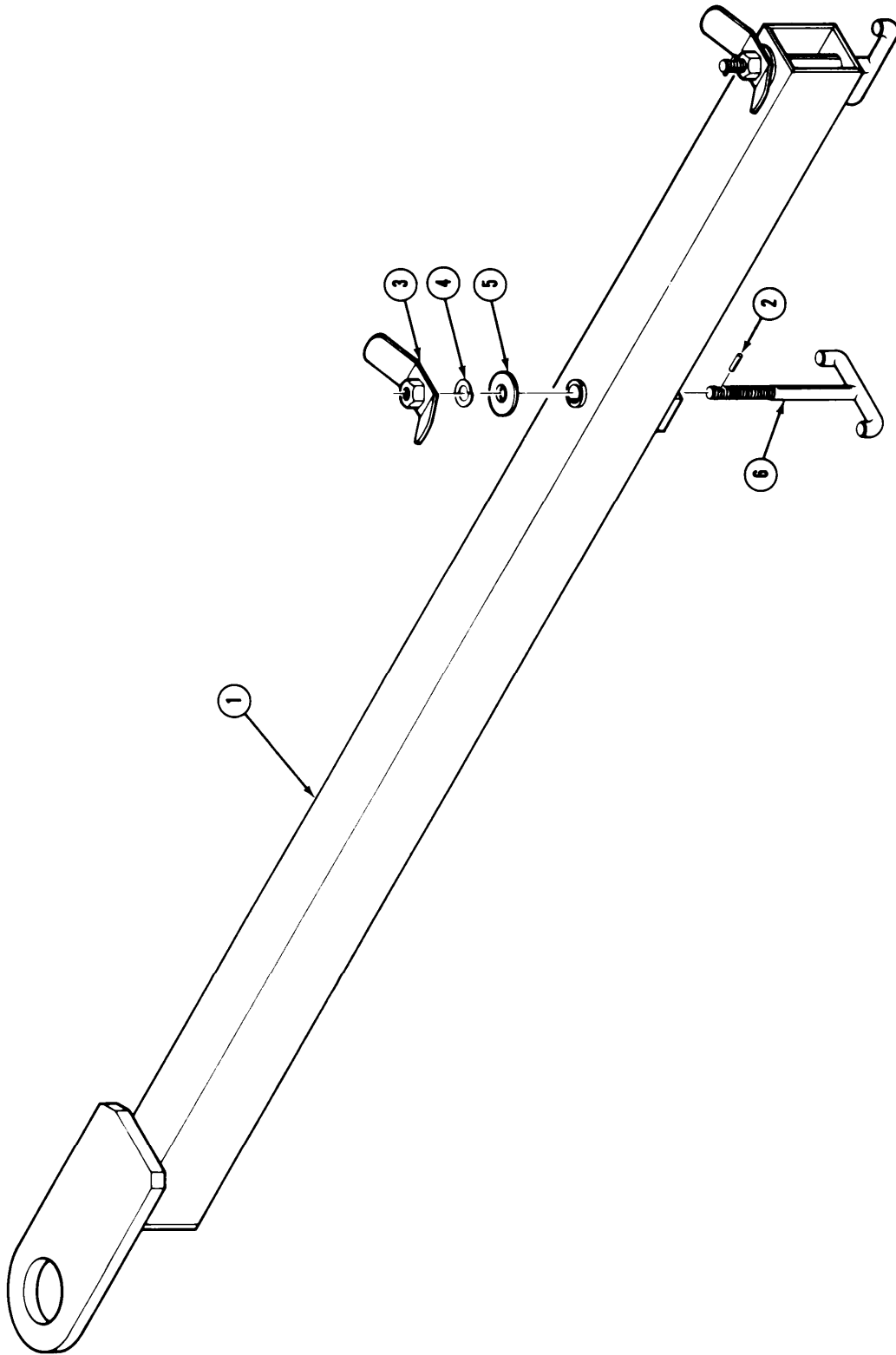

Figure 6-4. Towbar

FIG. & ITEM NO.	PART NUMBER	1	2	3	4	5	NOMENCLATURE	QTY
6-4	310802						TOWBAR ASSEMBLY	1
1	310807						.TOWBAR WELDMENT	1
2	81127						.PIN, ROLL	2
3	310816						.LOCK HANDLE ASSEMBLY	2
4	80764						.WASHER, SPLIT LOCK	2
5	80708						.WASHER, 3/4 "COML"	2
6	310813						.T-LOCK	2

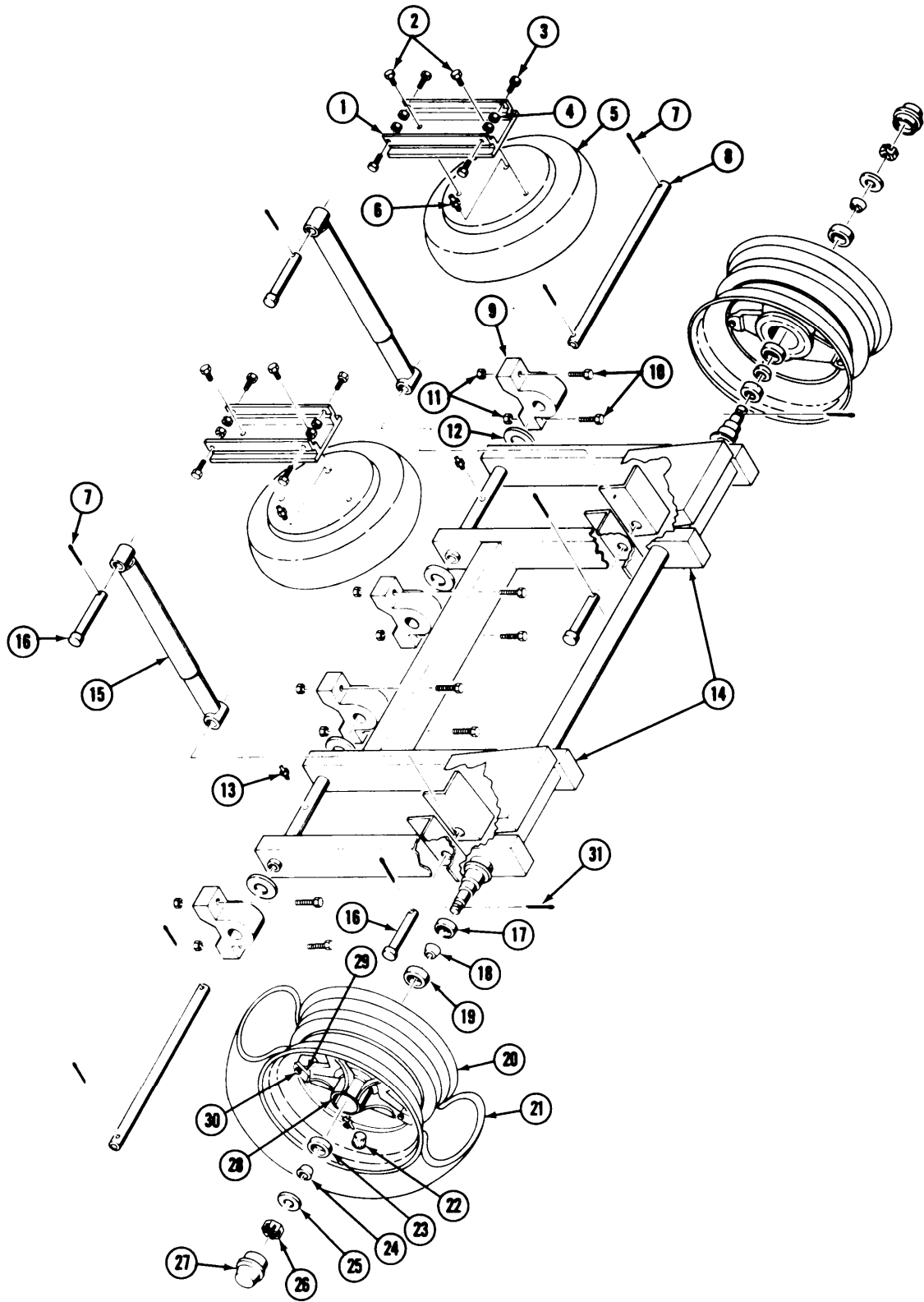

Figure 6-5. Suspension, Yoke, Wheels, Tires

FIG. & ITEM NO.	PART NUMBER	1 2 3 4 5 NOMENCLATURE	QTY
6-5		SUSPENSION, YOKE, WHEELS, AND TIRES ASSEMBLIES	
		.SUSPENSION ASSEMBLY	2
1	310829	..HANGER, AIR SPRING	2
2	80025	..CAPSCREW, HEX HD., 3/8-16 X 3/4 "COML"	4
3	80023	..CAPSCREW, HEX HD., 3/8-16 X 1 "COML"	8
4	80603	..LOCKNUT, HEX, 3/8-16 "COML"	8
	19060	..AIR SPRING ASSEMBLY	2
5	19061	..SPRING, AIR (1B12-306) (73842)	2
6	19047	..VALVE, AIR (1498P-8) (27783)	2
	310818	..YOKE WELDMENT, W/AXLE AND HUBS	1
7	81081	..PIN, COTTER, 3/16 X 2 "COML"	6
8	310830	..PIN, PIVOT	2
9	310828	..BLOCK, MOUNTING	4
10	80050	..CAPSCREW, HEX HD., 1/2-13 X 2 1/2 "COML"	8
11	80606	..LOCKNUT, HEX, 1/2-13 "COML"	8
12	80710	..WASHER, SPACER "COML"	4
13	81049	..FITTING, GREASE, 3/16 "COML"	2
14	310819	..YOKE WELDMENT	1
15	55504	..HYDRAULIC LIFT CYLINDER ASSEMBLY (SEE FIGURE 6-7 FOR DETAIL BREAKDOWN)	REF
16	81087	..PIN, CLEVIS	4
		..HUBS, WHEELS, TIRES ASSEMBLIES	2
17	18046	..SEAL (10-40) (15460)	2
		..INNER BEARING ASSEMBLY	2
18	18048*	...CONE (L68149) (COML)	2
19	18047*	...CUP (L68111) (COML)	2
	12800X145F60	..TIRE ASSEMBLY	2
20	12145X60	...RIM (T-600) (73842)	2
21	15800X145F	...TIRE, (8 X 14.5LRF) (COML)	2
22	19029	..VALVE, AIR (TR-416) (27783)	2
		..OUTER BEARING ASSEMBLY	2
23	18012*	...CONE (LM67048) (COML)	2
24	18013*	...CUP (LM67010) (COML)	2
25	19049	..WASHER (5-27) (15460)	2
26	19048	..NUT, SPINDLE (6-1) (15460)	2
27	18026	..CAP, GREASE (21-1) (15460)	2
28	25034	..HUB, W/CUPS (8-223-4) (15460)	2
29	19056	..CLAMP, RIM (15-2) (15460)	10
30	19055	..BOLT, RIM (7-36) (15460)	10
31	81083	..PIN, COTTER, 1/8 X 1 3/4 "COML"	2

* MATCHED PARTS; PROCURE AS A SET PER BEARING ASSEMBLY.

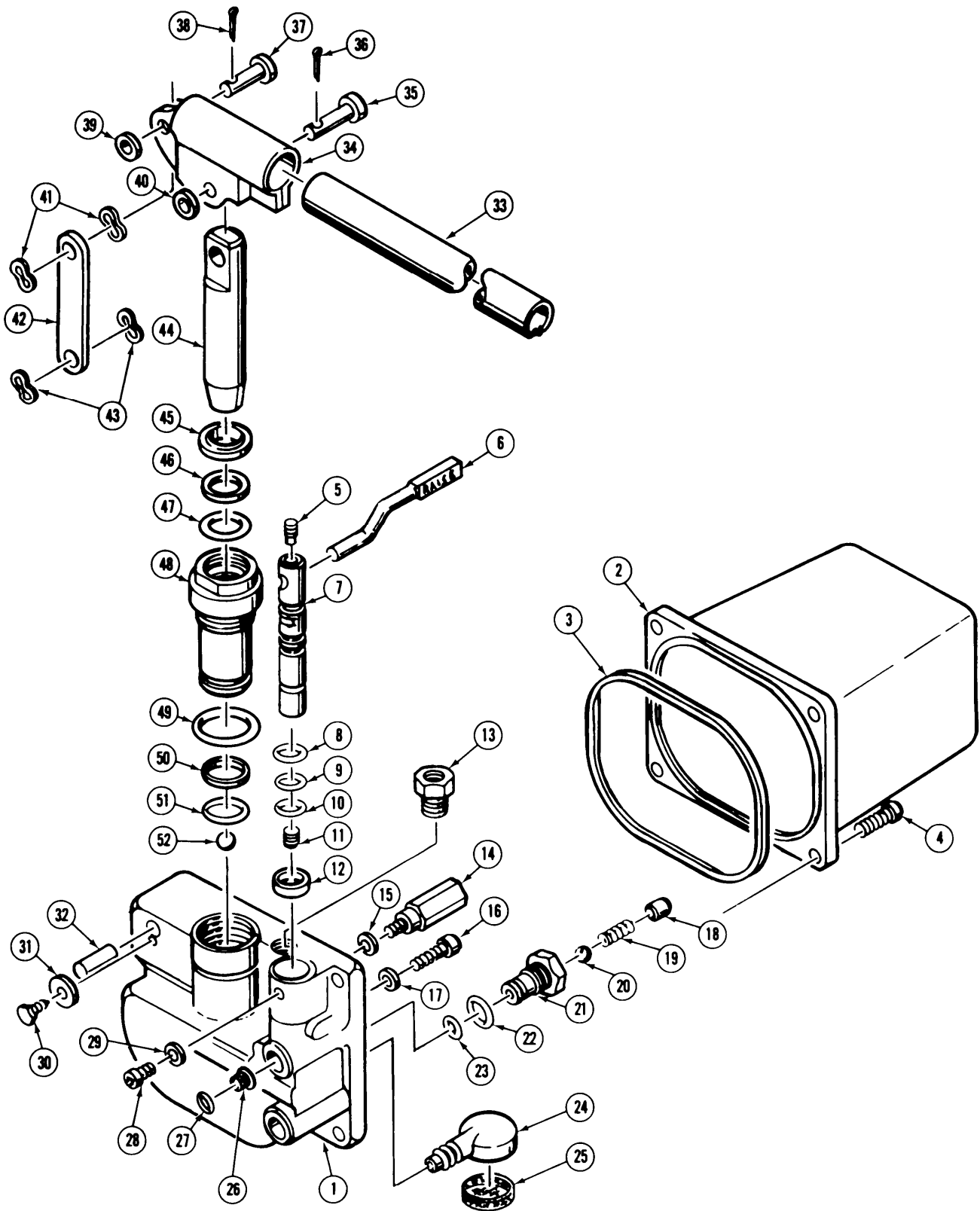

Figure 6-6. Hydraulic Pump

FIG. & ITEM NO.	PART NUMBER	1 2 3 4 5 NOMENCLATURE	QTY
6-6		HYDRAULIC PUMP ASSEMBLY	1
	55501	.PUMP (HP3004-41-14) (26953)	1
1	55510	.BODY (D8141.190) (26953)	1
2	55505	.RESERVOIR (C8115.025) (26953)	1
3	55521*	.O-RING (A8053.503) (26953)	1
4	55522	.CAPSCREW (B1005.028) (26953)	4
5	55548	.SETSCREW (A8040.027) (26953)	1
6	55547	.LEVER (A8041.157) (26953)	1
7	55511	.SPOOL (B8035.617) (26953)	1
8	55542*	.O-RING (A1008.503) (26953)	1
9	55541*	.O-RING (A8051.503) (26953)	1
10	55541*	.O-RING (A8051.503) (26953)	1
11	55544	.SCREW, ORIFICE (A9160.900) (26953)	1
12	55543*	.WIPER (A1028.476) (26953)	1
13	55550	.PLUG, BREATHER (FILL) (A9079.900) (26953)	1
14	55517	.VALVE, RELIEF (A8581.900) (26953)	1
15	55518*	.GASKET (S3.037) (26953)	1
16	55525	.PLUG (A1014.245) (26953)	1
17	55516	.GASKET (W222.37) (26953)	1
18	55515	.PLUG (B1322.028) (26953)	1
19	55526	.SPRING (A8160.110) (26953)	1
20	55527*	.BALL, 3/16" (B1005.016) (26953)	1
21	55513	.SEAT, OUTLET (A8126.190) (26953)	1
22	55523*	.O-RING (B1906.503) (26953)	1
23	55524*	.O-RING (B1011.403) (26953)	1
24	55519	.ADAPTER (A8042.038) (26953)	1
25	55520	.SCREEN (A8021.018) (26953)	1
26	55546	.SCREEN (A8040.018) (26953)	1
27	55545	.RING, RETAINING (A8015.049) (26953)	1
28	55551	.CAPSCREW (A8000.042) (26953)	1
29	55516*	.GASKET (W222.37) (26953)	2
30	55555	.SCREW (A8017.028) (26953)	1
31	55554	.WASHER (A8079.108) (26953)	1
32	55536	.PIN (A8115.016) (26953)	1
33	310832	.HANDLE, .PUMP	1
34	55531	.BEAM (A8019.060) (26953)	1
35	55532	.PIN (A8032.061) (26953)	1
36	55534	.PIN, COTTER (B1016.058) (26953)	1
37	55535	.PIN, BEAM LINK (A8033.061) (26953)	1
38	55534	.PIN, COTTER (B1016.058) (26953)	1
39	55537	.WASHER (A8023.108) (26953)	1
40	55537	.WASHER (A8023.108) (26953)	1
41	55538	.WASHER, WAVE (A8008.108) (26953)	2
42	55533	.LINK (A8037.062) (26953)	1
43	55538	.WASHER, WAVE (A8008.108) (26953)	2
44	55514	.PLUNGER (A8208.040) (26953)	1
45	55528*	.WIPER (A8064.476) (26953)	1
46	55529*	.BACKUP (B1115.565) (26953)	1
47	55530*	.O-RING (B1115.903) (26953)	1
48	55512	.CYLINDER (B8338.030) (26953)	1
49	55553*	.O-RING (B1019.403) (26953)	1
50	55552*	.BACKUP (B1019.565) (26953)	1
51	55540*	.O-RING (B1912.503) (26953)	1
52	55539*	.BALL, 1/4" (B1007.016) (26953)	1
	55500	REPAIR KIT, PUMP	1

* PART OF PUMP REPAIR KIT, P/N 55500

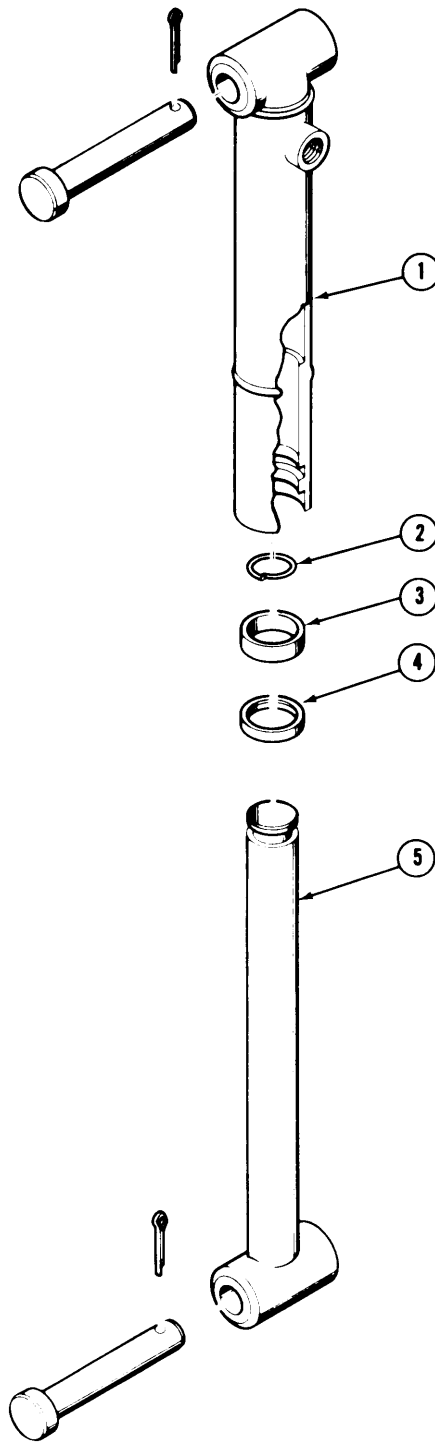

Figure 6-7. Hydraulic Lift Cylinders

FIG. & ITEM NO.	PART NUMBER	1	2	3	4	5	NOMENCLATURE	QTY
6-7	55504						HYDRAULIC LIFT CYLINDER ASSEMBLY	2
1	55556						.BARRELL (5386-02) (26278)	2
2	55558						.RING, LOCK (51727) (26278)	2
3	55561*						.WIPER (51087) (26278)	2
4	55560*						.SEAL, ROD (51234) (26278)	2
5	55557						.ROD (5386-18) (26278)	2
	55559						REPAIR KIT, CYLINDER	1

* PART OF CYLINDER REPAIR KIT, P/N 55559

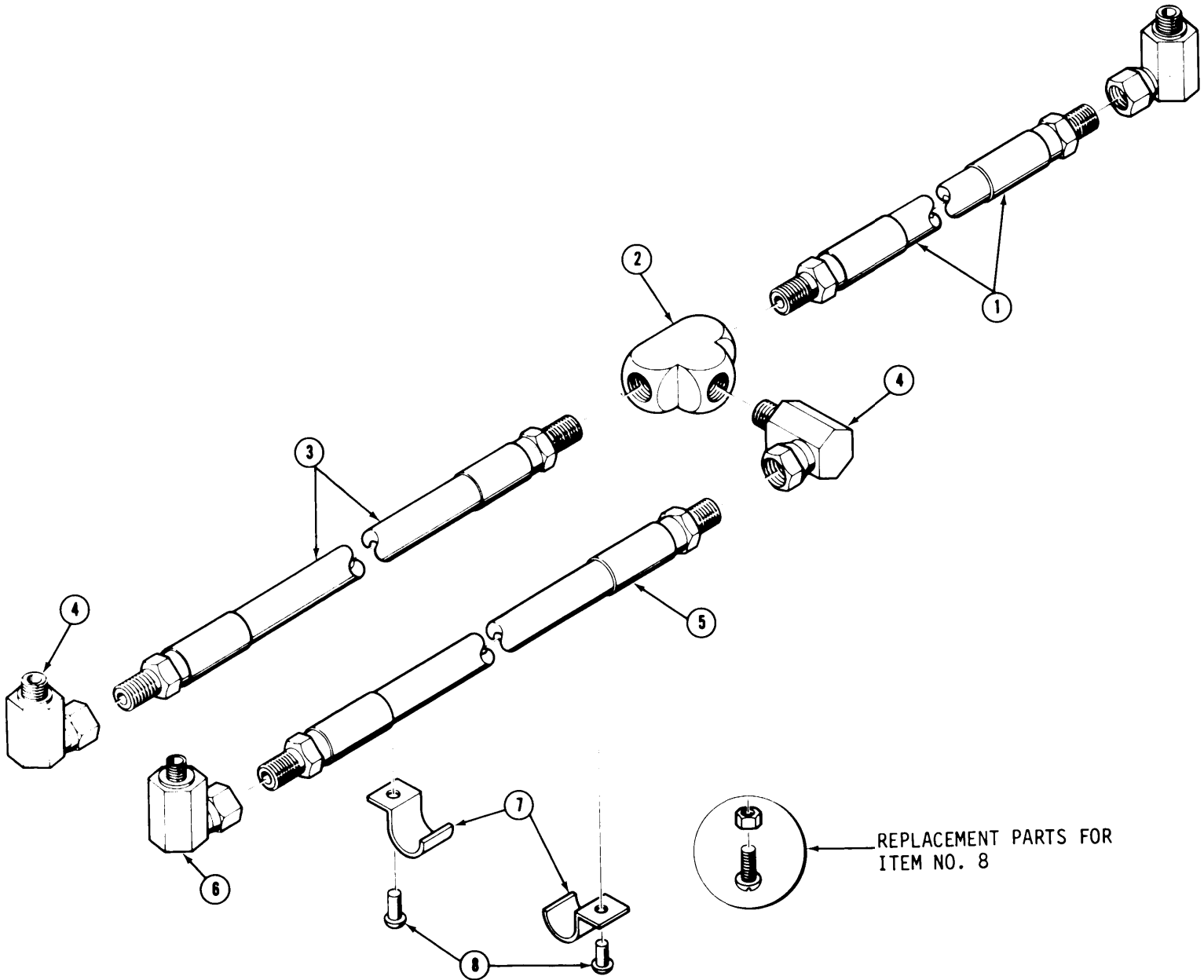

Figure 6-8. Hydraulic Lines and Fittings

FIG. & ITEM NO.	PART NUMBER	1	2	3	4	5	NOMENCLATURE	QTY
6-8							HYDRAULIC LINES AND FITTINGS ASSEMBLY	1
1	55503						.HOSE, HYDRAULIC, 1/4" X 27"	1
2	55508						.TEE, FEMALE	1
3	55503						.HOSE, HYDRAULIC, 1/4" X 27"	1
4	55507						.UNION, 90° ADAPTER	3
5	55502						.HOSE, HYDRAULIC, 1/4" X 44"	1
6	55506						.UNION, 90° L ADAPTER, 1/8 X 1/4	1
7	81026						.CLAMP, HOSE	2
8	81006						.RIVET	2
	80001*						.SCREW, SLOTTED RD. HD., 1/4 NC X 1" "COML"	2
	80601*						.NUT, HEX, 1/4 NC "COML"	2

* REPLACEMENT PARTS FOR ITEM NO. 8.

APPENDIX A
References

A-1. Scope

This appendix lists army regulations, field manuals, technical manuals, publication indexes and general references pertinent to the operation and maintenance of the RAMP, Mobile Loading.

A-2. Army Regulations

Accident Reporting And Records	AR 385-40
Logistics Assistance	AR 700-4
Supply Policy Below The Wholesale Level	AR 710-2
Requisitioning, Receipt, And Issue System	AR 725-50

A-3. Field Manuals

Chemical, Biological, Radiological And Nuclear Defense	FM 21-40
Manual For Wheeled Driver	FM 21-305
Metal Body Repair and Related Operations	FM 43-2
Shipment	FM 55-15

A-4 Preservation of Equipment for Shipment MIL-STD-1188

A-5 Technical Manuals

The Army Maintenance Management System (TAMMS)	DAPAM738-750
Air Transport	TM 55-450
Administrative Storage of Equipment	TM 740-90-1
Procedures For Destruction of Equipment To Prevent Enemy Use	TM 750-244-6
Bracing And Tie down Materiels For Rail Transport	TM 55-2200-001-12
Inspection, Care, And Maintenance Of Anti-Friction Bearings	TM 9-214
Welding Theory And Application	TM 9-237
Organizational Care, Maintenance And Repair of Pneumatic Tires And Inner Tubes	TM 9-2610-200-20

APPENDIX A
References

A-5. General References

Dictionary of United States Army Terms	AR 310-25
Authorized Abbreviations and Brevity Codes	AR 310-50
Military Symbols	FM 21-30

A-6. Publication Indexes

Consolidated Index Of Army Publications and Blank Forms (Includes Blank Forms; Doctrinal Training And Organizational Publications; Technical Manuals	DA PAM 310-1
---	--------------

SUPPLEMENTAL OPERATING, MAINTENANCE
AND REPAIR PARTS INSTRUCTION

FOR

RAMP, MOBILE LOADING, 16,000 LB
MAGLINE MODEL MDS-16-92-36-6F-AS-12C
NSN 3990-01-121-7758

TABLE OF CONTENTS

SECTION I - GENERAL		Page
1.1	Purpose	3
1.2	Scope	3
1.3	Description	3
1.4	Operating Concepts	3
1.5	Personnel & Training	3
1.6	Logistics Assistance	3
SECTION II- MAINTENANCE		
2.1	Maintenance Concept	4
2.2	Reliability and Maintainability	4
2.3	Modifications	4
2.4	Equipment Improvement Recommendations (EIR)	4
2.5	Preventative Maintenance Checks & Services (PMCS)	5
2.6	Shipment & Storage	11
2.7	Destruction to Deny Enemy Use	11

SECTION II

2.8 Basic Issue items (BILL) & Items Troop Installed or Authorized	11
2.9 Special Tools & Equipment	11
2.10 Maintenance & Operating Supplies	11
2.11 Maintenance Forms & Records	11

SECTION III- REPAIR PARTS SUPPLY

3.1 General	12
3.2 Prescribed Load List (PLL)	12
3.3 Authorized Stockage List (ASL)	12
3.4 Requisitioning Repair Parts (MILSTRIP)	12

APPENDIX

B - MAC	B-13
C - Lubricants	C-1

- 1.1 PURPOSE: To provide the user and support personnel supplemental operation maintenance and repair instructions applicable to the 16,000 lb Magline Mobile Ramp Model MDS-16-92-36-6F-AS-12C.
- 1.2 SCOPE: This SOMARPI applies to Department of the Army Units, Organizations and Activities that use and/or support the Ramps.
- 1.3 DESCRIPTION: The Mobile Ramp is wheel mounted with an automotive type axle and tapered roller bearings. It has an exclusive air cushioned suspension system for over the road towing at 25 MPH maximum and 5 MPH cross country. Vertical positioning of the Ramp through a range of 45 inches to 65 inches above ground level is done by a manually operated hydraulic system.
- 1.4 OPERATIONAL CONCEPT: The 16,000 lb Mobile Ramp is an elevating ramp for loading and unloading rail cars, truck, trailer and 8 ft wide military containers. It can also be used as a storage platform from grade or floor level in conjunction with power lift trucks and similar material handling devices.
- 1.5 PERSONNEL AND TRAINING: None required.
- 1.6 LOGISTICS ASSISTANCE (AR 700-4): US Army Tank-Automotive Commandos Field Maintenance Technician stationed at CONUS and OCONUS installations are available to furnish on-site training and/or technical assistance. Assistance can be obtained by contacting the appropriate Logistics Assistance Office (LAO) or TACOM, AMSTA-MVM, Warren, MI 48397 5000.

2.1 MAINTENANCE CONCEPT:

a. The 16,000 lb Mobile Ramp will not require new maintenance considerations. Maintenance operations can be accomplished within current maintenance support concept for Material Handling Equipment.

b. Nature and Extent of Maintenance:

(1) Maintenance Allocation Chart (MAC): Maintenance will be performed as necessary by the category indicated in the MAC to retain and/or restore serviceability. Units may exceed their authorized scope and function in the MAC when approved by the appropriate commander.

(2) Operator Maintenance: Operator maintenance is limited to daily preventative maintenance checks for hydraulic leaks, pump operation or damage to the ramp.

(3) Organizational Maintenance: Organizational maintenance is limited to minor repair or adjustment.

(4) Direct Support Maintenance: Direct Support Maintenance consists of on-site repair or return to Direct Support Shop for extensive repair.

(5) General Support or Depot Maintenance: General Support or Depot Maintenance will not be required. Due to the simplicity of operation and service, the ramp will be serviced and repaired at Organizational / Direct Support

2.2 RELIABILITY AND MAINTAINABILITY: Reliability and maintainability will be assessed through field evaluations.

2.3 MODIFICATIONS: Modifications will be accomplished by the end item manufacturer after acceptance/approval by TACOM\MERADCOM engineering.

2.4 EQUIPMENT IMPROVEMENT RECOMMENDATION (EIR): Equipment Improvement Recommendations will be submitted IAW DA PAM 738-750.

PREVENTIVE MAINTENANCE CHECKS & SERVICES (PMCS): The ramp is not a reportable item for readiness; however, daily inspection, for structural damage and hydraulic operation is advisable for PMCS.

OPERATOR

PREVENTIVE MAINTENANCE CHECKS AND SERVICES (PMCS)

2.5

GENERAL

Every mission begins and ends with the paperwork. There isn't much of it, but you have to keep it up. The forms and records you fill out have several uses. They are a permanent record of the services, repairs, and modifications made on your vehicle. They are reports to organizational maintenance and to your commander. And they are a checklist for you when you want to know what is wrong with the vehicle after its last use, and whether those faults have been fixed. For the information you need on forms and records, see DA PAM 738-750.

OPERATOR/CREW PREVENTIVE MAINTENANCE CHECKS AND SERVICES.

1. Do your before (B) PREVENTIVE MAINTENANCE just before you operate the ramp. Pay attention to the warnings and cautions.
2. If something doesn't work, troubleshoot it with the instructions in this manual or notify your supervisor.
3. Always do your PREVENTIVE MAINTENANCE in the same order so it gets to be a habit. Once you've had some practice, you'll spot anything wrong in a hurry.
4. When you do your PREVENTIVE MAINTENANCE, take along a rag or two.
5. While performing PMCS, observe warnings and cautions preceding those operations which could endanger your safety or result in damage to the equipment.

WARNING

Dry cleaning solvent P-D-680 is toxic and flammable. Wear protective goggles and gloves and use only in well-ventilated area. Avoid allowing solvent to contact skin, eyes and clothes, and don't breathe vapors. Do not use near open flame or excessive heat. If you become dizzy while using cleaning solvent, get fresh air immediately and get medical aid. If contact with skin or clothing is made, flush with water. If contact with eyes is made, wash your eyes with water and get medical aid immediately.

6. If anything looks wrong and you can't fix it, write it on your DA Form 2404. The number column is the source for the numbers used on the TM Number Column on DA Form 2404. If you find something seriously wrong, report it to organizational maintenance RIGHT NOW.

a. Keep it clean: Dirt, grease, oil and debris only get in the way and may cover up a serious problem. Clean as you work and as needed. Use dry cleaning solvent (P-D-680) to clean metal surfaces. Use soap and water when you clean rubber or plastic material.

b. Bolts, nuts and screws: Check that they are not loose, missing, bent or broken. You can't try them all with a tool, of course, but look for chipped paint, bare metal or rust around bolt heads. Tighten bolts, nuts and screws you find loose. Report it to organizational maintenance if you can't tighten it.

c. Welds: Look for loose or chipped paint, rust or gaps where parts are welded together. If you find a bad weld, report it to organizational maintenance.

d. Hoses and fluid lines: Look for wear, damage and leaks. Make sure clamps and fittings are tight. Wet spots show leaks, of course, but a stain around a fitting or connector can mean a leak. If a leak comes from a loose fitting or connector, tighten it. If something is broken or worn out, report it to organizational maintenance (refer to Maintenance Allocation Chart).

e. Ramp must be on level ground in order to get correct fluid level measurement.

10. It is necessary for you to know how fluid leaks affect the status of your equipment. The following are definitions of the types/classes of leakage you need to know to be able to determine the status of your equipment. Learn and be familiar with them and REMEMBER -- when in doubt, notify your supervisor.

LEAKAGE DEFINITIONS FOR OPERATOR/CREW PMCS

Class I	Seepage of fluid (as indicated by wetness or discoloration) not great enough to form drops.
Class II	Leakage of fluid great enough to form drops, but not enough to cause drops to drip from the item being checked/inspected.
Class III	Leakage of fluid great enough to form drops that fall from the item being checked/inspected.

CAUTION

Equipment operation is allowable with minor leakages (Class I or II). Of course, consideration must be given to the fluid capacity in the item/system being checked/inspected. When operating with Class I or II leaks, continue to check fluid levels as required on your PMCS. Class III leaks should be reported to your supervisor or Organizational Maintenance.

Operator/Crew Preventive Maintenance Checks and Services

NOTE: Within designated interval, these checks are to be performed in the order listed.

B-Before

Item No.	Interval B	Item To Be Inspected Procedure: Check for and have repaired, filled or adjusted as needed.	Equipment is not ready/ Available If:
1.	0	Check frame for broken welds, cracks or breaks.	Any cracks or breaks in main ramp structure.
2.	0	Check that deck grating is present and securely fastened.	Deck gratings missing, loose or not properly mounted.
3.	0	Check exterior and under ramp for hydraulic oil leaks <p style="text-align: center;"><u>NOTE</u></p> Ramp may be operated with Class I or II leaks but should be reported to Organizational Maintenance for evaluation and action.	Any class III leak in the hydraulic system.
4.	0	Check to verify that hydraulic system operates to lift and lower ramp.	Hydraulic lift does not operate.
5.	0	Check tires for obvious low or flat condition, Check that tires are installed, lug nuts are tight.	Tire(s) missing, flat or obviously low, lug nuts loose or missing, cuts or abrasions which could cause failure during operation.
6.	0	Check air spring inflation.	Air spring pressure obviously low.
7.	0	Check that safety chains are not missing, cracked or broken and that securing hooks are not defective or bent.	Safety chains missing, broken, defective or bent.
8.	0	Check that tow bar is present and is not bent, cracked or broken and will secure in towing position.	Tow bar missing, bent, cracked or broken. Tow bar will not secure in towing position.

ORGANIZATIONAL
PREVENTIVE MAINTENANCE CHECKS AND SERVICES (PMCS)

GENERAL

To make sure that your ramp is ready for operation at all times, inspect it systematically so you can discover any defects and have them corrected before they result in serious damage or failure. The charts on the next few pages contain your organizational PMCS. The item numbers indicate the sequence of minimum inspection requirements. If you're operating the ramp and notice something wrong which could damage the equipment if you continue operation, stop operation immediately.

Record all deficiencies and shortcomings, along with the corrective action taken, on DA Form 2404. The Item Number column is the source for the numbers used on the TM Number column on DA Form 2404.

ORGANIZATIONAL PREVENTIVE MAINTENANCE CHECKS AND SERVICES

1. The item numbers of the table indicate the sequence of the PMCS. Perform at the intervals shown below:

(a) Do your (Q) PREVENTIVE MAINTENANCE quarterly (every three months).

(b) Do your (A) PREVENTIVE MAINTENANCE annually (once every year).

2. If something doesn't work, troubleshoot it with the instructions in this manual or notify your supervisor.

3. Always do your preventive maintenance in the same order, so it gets to be a habit. Once you've had some practice, you'll spot anything wrong in a hurry.

4. If anything looks wrong and you can't fix it, write it down on your DA Form 2404. If you find something seriously wrong, report it to direct support as soon as possible.

WARNING

Dry cleaning solvent P-D-680 is toxic and flammable. Wear protective goggles and gloves and use only in well-ventilated area. Avoid allowing solvent to contact skin, eyes and clothes, and don't breathe vapors. Do not use near open flame or excessive heat. If you become dizzy while using cleaning solvent, get fresh air immediately and get medical aid. If contact with skin or clothing is made, flush with water. If contact with eyes is made, wash your eyes with water and get medical aid immediately.

(a) Keep it clean: Dirt, grease, oil and debris only get in the way and may cover up a serious problem. Clean as you work and as needed. Use dry cleaning solvent (P-D-680) to clean metal surfaces. Use soap and water when you clean rubber or plastic material.

(b) Bolts, nuts and screws: Check that they are not loose, missing, bent or broken. You can't try them all with a tool, of course, but look for chipped paint, bare metal or rust around bolt heads. Tighten any bolts, nuts, and screws that you find loose.

(c) Welds: Look for loose or chipped paint, rust or gaps where parts are welded together. If you find a bad weld, report it to direct support.

(d) Hoses and fluid lines: Look for wear, damage and leaks. Make sure clamps and fittings are tight. Wet spots show leaks, of course, but a stain around a fitting or connector can mean a leak. If a leak comes from a loose fitting or connector, tighten it. If something is broken or worn out, either correct it or report it to direct support (refer to MAC Chart).

5. It is necessary for you to know how fluid leaks affect the status of your equipment. The following are definitions of the types/classes of leakage you need to know to be able to determine the status of your equipment. Learn and be familiar with them and REMEMBER -- when in doubt, notify your supervisor.

LEAKAGE DEFINITIONS FOR ORGANIZATIONAL PMCS

- | | |
|-----------|---|
| Class I | Seepage of fluid (as indicated by wetness or discoloration) not great enough to form drops. |
| Class II | Leakage of fluid great enough to form drops, but not enough to cause drops to drip from the item being checked/inspected. |
| Class III | Leakage of fluid great enough to form drops that fall from the item being checked/inspected. |

NOTE

Perform Operator PMCS prior to or in conjunction with Organizational PMCS if:

1. There is a delay between the daily operation and the Organizational PMCS.
2. Regular operator is not assisting/participating.

Q-Quarterly

A-Annually

Item No.	Inter-val		Item To Be Inspected Procedure: Check for and repair, fill or adjust as necessary.
	G	A	
1			Wheels & Tires
	0	0	a. Wheel Assembly: Check lug nuts for tightness, torque to 85-90 ft. lbs. b. Lubricate inner and outer wheel bearings. Ref. para. 5.5.6.3
2			Tires & Tubes
	0		Check tire pressure (75-85 psi).
	0		Check valve stem assembly for leaks (tubeless tires only).
	0		Check for tire cuts, cracks and dry rot.
3			Frame Assembly, Brackets & Hangers
	0		a. Inspect and tighten lifting ring mounting bolts as required.
	0		b. Tighten mounting bolts on frame and safety chain assembly.
	0		c. Replace shackle pins if loose or broken. Ref Table 5-2.
	0		d. Check main frame assembly for broken or cracked weldments. Report broken or cracked weldments to DS maintenance.
4			Air Spring Assembly
	0		Visually inspect for cracks/leaks in the air bag area and valve assembly.
5			Hydraulic Pump
	0		a. Inspect hydraulic pump for leaks. (Report Class III leaks to DS Maintenance).
	0		b. Service pump in accordance with Ref. para. 5.5.9.1.2
6			Hydraulic Lift-Cylinders
	0		Inspect hydraulic lift cylinders for leaks and damage. Report lift cylinders requiring repair to DS Maintenance.
7			Hydraulic Lines and Fittings
	0		Inspect hydraulic lines and fittings for breaks, sharp bends or leaks.
8			Suspension System (Magline Model MDS-16-96-36-6F-CS)
	0		Check for cracked or broken springs and missing or broken mounting hardware.

2.6 SHIPMENT AND STORAGE:

TM 10-3990-203-13&P

a. Refer to ASTM-D-39151-82:procedures covering preservation of equipment for shipment. General procedures for shipment are found in FM 55-15, with more specific information in TM 55-2200-001-12 for rail,

b. Administrative Storage: Refer to TM 740-90-1.

c. Weight Classification: The weight of the end item is 5250 lbs.

2.7 DESTRUCTION TO DENY ENEMY USE: Refer to TM 750-244-3 for instructions governing destruction of equipment to prevent enemy use.

2.8 BASIC ISSUE ITEMS LIST (BIIL) & ITEMS TROOP INSTALLED OR AUTHORIZED:

None.

2.9 SPECIAL TOOLS & EQUIPMENT: None.

2.10 MAINTENANCE AND OPERATING SUPPLIES: Appendix C.

2.11 MAINTENANCE FORMS AND RECORDS: None.

SECTION III - REPAIR PARTS SUPPLY

3.1 GENERAL:

a. The basic policies and procedures in AR 710-2 and AR 725-50 are generally applicable to repair parts management for Material Handling Equipment (MHE) items.

b. Manufacturer's parts manuals are furnished with this ramp instead of Department of the Army Repair Parts and Special Tool List (RPSTL). However, a RPSTL will be furnished at a later date.

c. National Stock Numbers (NSNS) are initially assigned to Stock Type ("P Coded") items. These will be shown in the RPSTL when furnished later.

d. Automatic Processing (AUTODIN) of Federal Supply Code Manufacturer (FSCM) part number requisitions, without edit for matching NSNS is authorized.

e. Non-NSN repair parts are available from commercial sources and may be purchased locally IAW AR 710-2 and AR 725-50.

3.2 PRESCRIBED LOAD LIST (PLL): N/A.

3.3 AUTHORIZED STOCKAGE LIST (ASL): N/A.

3.4 REQUISITIONING REPAIR PARTS (MILSTRIP): Requisitions (DD Form 1348 Series) will be prepared in accordance with the MILSTRIP format (AR 725-50). Distribution Codes and project codes as applicable will be used.

MAINTENANCE ALLOCATION CHART
FOR
RAMP, MOBILE LOADING, 16,000 LB
MAGLINE MODEL MDS-16-92-36-6F-AS-12C
NSN 3990-01-121-7758

SECTION I - Introduction

1. General: This Maintenance Allocation Chart (MAC) designates responsibility for performance of maintenance functions to specific maintenance categories.
2. Maintenance Functions: Maintenance functions are defined as follows:
 - a. Inspect: To closely and critically examine (e.g., sight, sound, or feel) an item to detect errors, flaws, wear, etc., and to determine its condition and serviceability by comparing its physical, mechanical/electrical characteristics within established standards.
 - b. Test: To verify serviceability and detect incipient failures by measuring the mechanical or electrical characteristics of an item and comparing those characteristics with prescribed standards.
 - c. Service: Operations required periodically to keep an item in proper operating condition; i.e., to clean (decontaminate), to preserve, to drain, to paint or to replenish fuel, lubricants, hydraulic fluids or compressed air supplies.
 - d. Adjust: To maintain, within prescribed limits, by bringing into proper or exact position, or by setting the operating characteristics to specified parameters.
 - e. Align: To adjust specified variable elements of an item to bring about optimum or desired performance.

f. Calibrate: To determine and cause corrections to be made or to be adjusted on instruments or test measuring and diagnostic equipment used in precision measurement. Consists of comparisons of two instruments, one of which is a certified standard of known accuracy, to detect and adjust any discrepancy in the accuracy of the instrument being compared.

g. Install: The act of emplacing, seating or fixing into position an item, part or module (component or assembly) in a manner to allow the proper functioning of an equipment or system.

h. Replace: The act of substituting a serviceable like type part, sub-assembly or module (component or assembly) for an unserviceable counterpart

i. Repair: The application of maintenance services (inspect, test, service, adjust, align, calibrate, or replace) or other maintenance actions (welding, grinding, riveting, straightening, facing, remachining, or re-surfacing) to restore serviceability to an item by correcting specific damage, fault, malfunction, or failure in a part, subassembly, module (components or assembly), and item or system.

j. Overhaul: That maintenance effort (service/action) necessary to restore an item to a completely serviceable/operational condition as Prescribed by maintenance standards (i.e., DMWR) in appropriate technical publications. Overhaul is normally the highest degree of maintenance performed by the Army. Overhaul does not normally return an item to like new condition.

k. Rebuild: Consists of those services/actions necessary for the restoration of unserviceable equipment to a like new condition in accordance with original manufacturing standards. Rebuild is the highest degree of materiel maintenance applied to Army equipment. The rebuild operation includes the act of returning to zero those age measurements (hours/miles, etc.) considered in classifying Army equipment/components.

3. Column Entries: Columns used in the MAC are explained below:

a. Column 1 - Group Number: Column One (1) lists group numbers, the purpose of which is to identify components, assemblies, subassemblies and modules with their next higher assemblies.

b. Column 2 - Component/Assembly: Column Two (2) contains the noun names of components, assemblies, subassemblies and modules for which maintenance is authorized.

c. Column 3 - Maintenance Functions: Column Three (3) lists the functions to be performed on the item listed in Column 2.

d. Column 4 - Maintenance Category: Column Four (4) specifies, by the listing of a "work time" figure in the appropriate subcolumn(s), the category of maintenance authorized to perform the function listed in Column 3. This figure represents the active time required to perform that maintenance function at the indicated category of maintenance. If the number or category of the tasks within the listed maintenance function vary at different maintenance categories, appropriate "work time" figures will be shown for each category. The number of man-hours specified by the "work time" figure represents the average time required to restore an item (assembly, subassembly, component, module, end item or system) to a serviceable condition under typical field operating conditions. This time includes preparation time, troubleshooting quality assurance/quality control time in addition to the time re-perform the specific tasks identified for the maintenance functions authorized in the maintenance chart. This figure does not include any time for performance of preliminary tasks listed elsewhere in the MAC, e.g., removal of engine under repair of fuel pump when the engine is listed separately

in the MAC. The symbol designations for various maintenance categories remain as follows.

C - Operator/Crew (unit)

O - Organizational Maintenance (unit)

F - Direct Support Maintenance (Intermediate)

H - General Support Maintenance (Intermediate)

D - Depot Maintenance

e. Column 5 - Tools and Equipment: Column Five (5) specifies by code, those common tool sets (not individual tools), test and support equipment required to perform the designated functions.

SECTION II. MAINTENANCE ALLOCATION CHART

GROUP NUMBER (1)	COMPONENT/ASSEMBLY (2)	MAINTENANCE FUNCTION (3)	MAINT LEVEL					TOOLS & EQUIP. (5)	REMARKS (6)
			UNIT		INTMED				
			C	O	F	H	D		
13	Wheel and Tracks							55719	
1311	Wheel Assembly: Nuts, Studs, Bearings, Seals, Hubs, and Drums	Service Replace Repair		0.7 0.7	1.5				
1313	Tires, Tubes, and Air Spring	Service Replace Repair	0.1	0.3 0.3					
15	Frame, Towing Attachments, Drawbars, and Articulation System								
1501	Frame Assembly, Brackets, and Hangers	Inspect Service Repair	0.2	0.3	.0				
22	Body, Chassis or Hull, and Accessory Items								
2202	Accessory Items: Reflectors	Inspect Replace	0.1	.2					
24	Hydraulic Lift Components								
2401	Hydraulic Pump	Service Replace Repair		.2 .5	5				
2405	Hydraulic Lift Cylinders	Replace Repair		.7	5				
2406	Hydraulic Lines and Fittings	Inspect Replace	0.1	.3					

*MAINTENANCE LEVELS:

C- OPERATOR/CREW = UNIT
O- ORGANIZATIONAL

F- INTERMEDIATE DIRECT SUPPORT
H- INTERMEDIATE GENERAL SUPPORT

D - DEPOT

APPENDIX C

LUBRICANTS

COMPONENT	NSN	QTY/WT	REMARKS
CHASSIS	9150-00-190-0905	5 LB. CAN/127 LB. DRUM	MIL-G-10942B
HYD. JACK	9150-00-252-6383	1 GAL. CAN	(OHA)MIL-H-5606
WHEEL BEARINGS	9150-00-663-9795	FLUID HYD. PETRO BASE	MIL-G-18790 (81349)

By Order of the Secretary of the Army:

JOHN A. WICKHAM, JR.
General, United States Army
Chief of Staff

Official:

R.L. DILWORTH
Brigadier General United States Army
The Adjutant General

Distribution:

To be distributed in accordance with DA Form 12-25 , Operator's,
Unit, Intermediate Direct Support Maintenance Manual requirements for Ramp
Mobile, Loading, 16,000 LB. .



SOMETHING WRONG WITH THIS PUBLICATION?

THEN... JOT DOWN THE DOPE ABOUT IT ON THIS FORM. CAREFULLY TEAR IT OUT. FOLD IT AND DROP IT IN THE MAIL!

FROM: (PRINT YOUR UNIT'S COMPLETE ADDRESS)

Cdr 1st Inf Bn
ATTN: CPT J.T.Kirk
Key West, FL 33040

DATE SENT Date you send 2028-2

PUBLICATION NUMBER
TM10-3990-203-13&P

PUBLICATION DATE
Date of TM

PUBLICATION TITLE Operator's, Unit,
Intermediate Direct Support Maint
Manual

BE EXACT PIN-POINT WHERE IT IS

PAGE NO	PARA-GRAPH	FIGURE NO	TABLE NO
1	2	6	

IN THIS SPACE TELL WHAT IS WRONG AND WHAT SHOULD BE DONE ABOUT IT:

Page 1, para 2, figure 6; the paragraph does not relate to the nomenclature. Please correct this mistake.

SAMPLE

PRINTED NAME, GRADE OR TITLE AND TELEPHONE NUMBER

CPT J. T. Kirk, AUTOVON 721-1701

SIGN HERE

CAPTAIN JAMES T. KIRK

FILL IN YOUR
UNIT'S ADDRESS



DEPARTMENT OF THE ARMY

SAMPLE

FIELD BACK

OFFICIAL BUSINESS

TEAR ALONG PERFORATED LINE

Commander
US Army Tank-Automotive Command
ATTN: AMSTA-MB
Warren, Michigan 48397-5000

FILL IN YOUR
UNIT'S ADDRESS



FOLD BACK

DEPARTMENT OF THE ARMY

OFFICIAL BUSINESS

Commander
US Army Tank-Automotive Command
ATTN: AMSTA-MB
Warren, Michigan 48397-5000

TEAR ALONG PERFORATED LINE

FILL IN YOUR
UNIT'S ADDRESS



FOLD BACK

DEPARTMENT OF THE ARMY

OFFICIAL BUSINESS

Commander
US Army Tank-Automotive Command
ATTN: AMSTA-MB
Warren, Michigan 48397-5000

TEAR ALONG PERFORATED LINE

FILL IN YOUR
UNIT'S ADDRESS



FOLD BACK

DEPARTMENT OF THE ARMY

OFFICIAL BUSINESS

TEAR ALONG PERFORATED LINE

Commander
US Army Tank-Automotive Command
ATTN: AMSTA-MB
Warren, Michigan 48397-5000

THE METRIC SYSTEM AND EQUIVALENTS

LINEAR MEASURE

1 Centimeter = 10 Millimeters = 0.01 Meters = 0.3937 Inches
 1 Meter = 100 Centimeters = 1000 Millimeters = 39.37 Inches
 1 Kilometer = 1000 Meters = 0.621 Miles

WEIGHTS

1 Gram = 0.001 Kilograms = 1000 Milligrams = 0.035 Ounces
 1 Kilogram = 1000 Grams = 2.2 Lb.
 1 Metric Ton = 1000 Kilograms = 1 Megagram = 1.1 Short Tons

LIQUID MEASURE

1 Milliliter = 0.001 Liters = 0.0338 Fluid Ounces
 1 Liter = 1000 Milliliters = 33.82 Fluid Ounces

SQUARE MEASURE

1 Sq. Centimeter = 100 Sq. Millimeters = 0.155 Sq. Inches
 1 Sq. Meter = 10,000 Sq. Centimeters = 10.76 Sq. Feet
 1 Sq. Kilometer = 1,000,000 Sq. Meters = 0.386 Sq. Miles

CUBIC MEASURE

1 Cu. Centimeter = 1000 Cu. Millimeters = 0.06 Cu. Inches
 1 Cu. Meter = 1,000,000 Cu. Centimeters = 35.31 Cu. Feet

TEMPERATURE

$\frac{5}{9}(\text{°F} - 32) = \text{°C}$
 212° Fahrenheit is equivalent to 100° Celsius
 90° Fahrenheit is equivalent to 32.2° Celsius
 32° Fahrenheit is equivalent to 0° Celsius
 $\frac{9}{5}(\text{°C} + 32) = \text{°F}$

APPROXIMATE CONVERSION FACTORS

TO CHANGE	TO	MULTIPLY BY
Inches	Centimeters	2.540
Feet	Meters	0.305
Yards	Meters	0.914
Miles	Kilometers	1.609
Square Inches	Square Centimeters	6.451
Square Feet	Square Meters	0.093
Square Yards	Square Meters	0.836
Square Miles	Square Kilometers	2.590
Acres	Square Hectometers	0.405
Cubic Feet	Cubic Meters	0.028
Cubic Yards	Cubic Meters	0.765
Fluid Ounces	Milliliters	29.573
Pints	Liters	0.473
Quarts	Liters	0.946
Gallons	Liters	3.785
Ounces	Grams	28.349
Pounds	Kilograms	0.454
Short Tons	Metric Tons	0.907
Pound-Feet	Newton-Meters	1.356
Pounds per Square Inch	Kilopascals	6.895
Miles per Gallon	Kilometers per Liter	0.425
Miles per Hour	Kilometers per Hour	1.609

TO CHANGE	TO	MULTIPLY BY
Centimeters	Inches	0.394
Meters	Feet	3.280
Meters	Yards	1.094
Kilometers	Miles	0.621
Square Centimeters	Square Inches	0.155
Square Meters	Square Feet	10.764
Square Meters	Square Yards	1.196
Square Kilometers	Square Miles	0.386
Square Hectometers	Acres	2.471
Cubic Meters	Cubic Feet	35.315
Cubic Meters	Cubic Yards	1.308
Milliliters	Fluid Ounces	0.034
Liters	Pints	2.113
Liters	Quarts	1.057
Liters	Gallons	0.264
Grams	Ounces	0.035
Kilograms	Pounds	2.205
Metric Tons	Short Tons	1.102
Newton-Meters	Pound-Feet	0.738
Kilopascals	Pounds per Square Inch	0.145
Kilometers per Liter	Miles per Gallon	2.354
Kilometers per Hour	Miles per Hour	0.621

